

## Direct Current and Alternative Current Based Solar Micro-Grid in Rural Energy Infrastructure

Vivek Kumar Singh\*, Lakshman Ravi Teja and Jitendra Tiwari

University of Coimbra, MIT Portugal Program, Coimbra, Portugal

### Abstract

In India kerosene uses as primary source of lighting- 43% of rural and 7.1% of urban households, even most populated African countries (Uganda, Ethiopia, and Kenya) more than 60% of the population relies on kerosene as the primary lighting fuel. Though they have access to grid electrification the unreliable supply leaves them in complete darkness and hence compelling them to think of alternatives. Poor electrification and unreliable supply lead to usage of kerosene based lighting devices such as kerosene lamps, which not only provides lowly quality illumination but also results in hazardous smoke. Off-grid electrification can provide an alternative solution for many low demand users at lower cost than grid extension and market growth of rural energy service. Costs of off-grid technologies have decreased significantly over the last few years hence making it affordable. Modern micro grid has come up with a way to make lighting system accessible to most of the rural households. Solar based renewable energy technologies extensively development in the last decade, the Solar photo voltaic cell converts light energy into direct current using the photovoltaic effect. Battery devices storing the extra power generated at day time and used during nights. Inverters and power Store Electronic Systems are used to convert direct current power generated by solar photo voltaic systems to alternative current, and utilization of direct current /alternative current in renewable energy power system at higher capital cost. But the internal rate of interest makes it superior to other system. This paper a latest researcher's review of assessment of Direct current (DC) and Alternative current (AC) based Solar Micro-grid in rural community. The paper is therefore structured as follows: overview of micro-grid AC and DC system with case studies. Sensibility analysis in Compression with decentralized Diesel Genset (DG) based on Net present value (NPV) Internal rate of interest (IRR) for DG set 92% (not included as environmental economics), the IRR for solar micro-grids 50% and solar micro-grids with Government subsidy 80%. Opportunities and challenges involved in the implementation of solar mini grid in rural energy infrastructure.

**Keywords:** Decentralized rural energy; Micro grid; Rural energy infrastructure; Solar photovoltaic

### Introduction

Renewable energy sources deliver 16% of the total world energy demand [1]. For 10% of all energy from biomass, [2] and 3.4% from hydroelectricity and 3% accounted for another new renewables (small hydro, modern biomass, wind, solar, geothermal and biofuels) [3]. Renewable energy sources that meet the requirements of domestic energy have the potential to provide energy services with zero or almost zero emissions of both air pollutants and greenhouse gases [4]. Harvesting the renewable energy in decentralized manner is one of the options to meet the rural and small scale energy needs in a reliable, affordable and environmentally sustainable way [5,6].

Photovoltaic (PV) technology is one of the first of several renewable energy technologies, [7] which has been adopted worldwide as well as in India to meet the basic energy needs of rural areas that are not connected to the network. Even so, the growth rate of 30-50% of the global annual average PV is mainly driven by the markets of industrialized countries such as Spain, Germany, USA, Italy, South Korea and Japan [8].

The use of solar photo voltaic system to electrify rural areas has both social and economic benefits [9]. The power generated using this system can be used to operate motor and pumps used for irrigation, storing consumable agricultural products, and many usages [10]. As for the social benefits are concerned electricity allows school going children to study at night, women do some entrepreneurial activity and so on; it contributes to better health allows switching from inferior biomass fuels to clean electricity thereby enhancing indoor air quality [11]. It also gives rural people, lots of opportunities to get access telecommunications and mass media [12]. It also helps to reduce carbon footprint and in order

as to minimize fossil fuel consumption. In India for many decades rural electrification has been an important policy agenda for both the central as well as the state governments. In November 2009, India ministry of new renewable energy approved the Jawaharlal Nehru National Solar mission (JNNSM) the goal of deploying 20 gigawatts (GW) of grid - connected solar power and 2 GW of off grid solar by 2022 [13].

In India, in 2011, an estimated one in three households reported kerosene as their primary source of lighting-43% of rural and 7.1% of urban households). In the lowest four socioeconomic declines of India, 60% of households use kerosene for lighting [14]. In several of the most populated African countries, including Uganda, Ethiopia, and Kenya, more than 60% of the population relies on kerosene as the primary lighting fuel [15]. Though they have access to grid electrification the unreliable supply leaves them in complete darkness and hence compelling them to think of alternatives. Poor electrification and unreliable supply lead to usage of kerosene based lighting devices such as kerosene lamps, which not only provides poor quality illumination but also results in

\*Corresponding author: Vivek Kumar Singh, University of Coimbra, MIT Portugal Program, Coimbra, Portugal, Tel: +351923227163; E-mail: [vivjsingh@gmail.com](mailto:vivjsingh@gmail.com)

Received August 11, 2015; Accepted December 08, 2015; Published December 10, 2015

Citation: Singh VK, Teja LR, Tiwari J (2015) Direct Current and Alternative Current Based Solar Micro-Grid in Rural Energy Infrastructure. J Fundam Renewable Energy Appl 5: 196. doi:10.4172/20904541.1000196

Copyright: © 2015 Singh VK, et al. This is an open-access article distributed under the terms of the Creative Commons Attribution License, which permits unrestricted use, distribution, and reproduction in any medium, provided the original author and source are credited.

hazardous smoke [15]. Off-grid electrification can provide an alternative solution for many low demand users at lower cost than grid extension and market growth of rural energy service. Costs of off-grid technologies have decreased significantly over the last few years hence making it affordable for some users. But many still cannot afford it. Taking this fact into account the Modern micro grid has come up with a way to make lighting system accessible to most of the rural households.

This paper a latest researchers' review of assessment of Direct current (DC) and alternative current (DC) based Solar Micro-grid in rural community. The paper is therefore structured as follows: overview of micro-grid AC and DC system with case studies. Sensitivity analysis in Comparison with decentralized Diesel Genset (DG). Opportunities and challenges involved in the implementation of solar mini grid in rural energy infrastructure

## Overview of Solar Micro Grid System

A Microgrid is any small or local electric power system that is independent of the bulk electric power network. For example, it can be a combined heat and power system based on a natural gas combustion engine (which cogenerates electricity and hot water or steam from water used to cool the natural gas turbine), or diesel generators, renewable energy, or fuel cells. A Microgrid can be used to serve the electricity needs of data centers, colleges, hospitals, factories, military bases, or entire communities (i.e., "village power") [16].

### Solar photovoltaic system

The amount of sunlight striking the earth's atmosphere continuously is  $1.75 \times 10^{15}$  TW. Considering a 60% transmittance through the atmospheric cloud cover,  $1.05 \times 10^{15}$  reach the earth's surface continuously. If the irradiance on only 1% of the earth's surface could be converted into the electric energy with 10% efficiency, it would provide a resource base of  $10^5$  TW, whereas the total global energy needs for 2050 are projected to be about 25-30 TW. The present state of solar energy technologies is such as single solar cell efficiencies have reached over 20%, Photovoltaic (PV) is a technology that converts light, directly into electricity [17]. To explain the Solar Photovoltaic panel in Simple terms, Photovoltaics is the direct conversion of light into electricity at the atomic level. Semiconductor materials exhibit a property known as the photoelectric effect that causes them to absorb photons of sunlight and higher state of energy release electrons, crating Direct Current (DC) electricity. The efficiency of system is about 4-40% against to semiconductor used in construction of PV arrays. The PV arrays made up of mono crystalline converts 15% of solar power reaching its surface into electricity, while multi crystalline converts only 12% of solar power reaching its surface into electricity this percentage further drop down to 6% and 4% in case of amorphous silicon cells (also called as thin film PV cells), cadmium telluride and copper indium PV cells. The efficiency of the cell increases with increase in cost of the PV arrays [17]. Recent development in PV technology has led to a development of high efficient PV arrays know as multi-junction PV, which operates at an efficiency of 40% [17]. The efficiency of the PV arrays can be improved by 30-50% by using 2 axis solar tracking system in sunny days and by 50% by using horizontal axis orientation instead of 2 axis solar tracking system during cloudy days [18]. The efficiency of the material can be further improved by using mirrors and lens to concentrate solar rays into PV arrays [19].

### Battery

The solar light is available throughout the day the excess energy generated must be stored to provide power during night [20]. Batteries are devices which stores electrical energy in the form of chemical energy

and convert that energy into electricity, the batteries used in PV system are charged and discharged, often; hence they are specially designed to meet the stronger requirements than regular batteries. It also helps to produce constant output from PV system where the input is often fluctuating [17]. The specially design Solar tubular acid led batteries 3-5 years life span depends on connected load to system, charging cycle and operating temperature. The climate can be extremely hot, dry and dusty, which can affect the productivity of the panel and create additional wear and tear to the equipment. Hot climate reduces the life increasing the performance on the contrary low temperate increases life but reduces the performance. In order to optimize the performance and the life of the battery entrepreneurs were trained not to utilize the battery to its fullest capacity in order to avoid over-draining.

### Inverters

A power inverter, is an electronic device or circuitry that convert direct current (DC) to alternating current (AC), to meet the connected AC power demand in load side. The input voltage, output voltage and frequency, and overall power handling depend on the design of the specific device or circuitry. The inverter does not produce any power; the power is provided by the Solar PV System.

### MPPT Maximum Power Point Tracking (MPPT)

Recently the researcher developed a component to improve the charging cycle of batteries, MPPT the influence of various parameters on the performance of a photovoltaic system. MPPT system that produces a non-linear output efficiency between solar irradiation, temperature and total resistance (load) to obtain maximum power for any given environment.

### Power Distribution Network (PDN)

The Power distribution network design is essential for proper service on demand side. A power distribution network (PDN) consists of poles, conductors, insulators, wiring/cabling; service lines, internal wiring and appliances to individual households like compact fluorescent lamp, television, fan, radio, etc. [8] 40-50% cost of PDN plays a huge role while determining the project planning a micro grid PV system.

## Micro Grid System Technology

### Alternative current based Solar Micro-grid

AC Micro grid system consists of a solar panel, charge controller MPPT, inverter, batteries and wiring/cabling; service line. AC micro grid system design based on the connected load and appliance. AC Micro grid system technology point out as huge losses in a transmission line. While during mapping of system layout for avoiding the maximum losses by using copper wiring costly solution or small power distribution network). An AC mini-grid is expandable and modular with standardized system components. A major advantage of such a system is that it can easily grow to meet increased consumption demands simply by adding more producers to the electricity. A potential disadvantage to AC mini-grids as slightly lower system efficiency. This is a result of the more frequent conditioning of the electricity because all energy stored in the batteries must be rectified during charging and inverted during discharging [21-23] (Figure 1).

### Direct current based solar micro-grid

DC Micro grid system consists of a solar panel, charge controller MPPT, batteries and wiring/cabling; service line. DC micro grid system operation best suitable performs in a rural area with only DC appliance

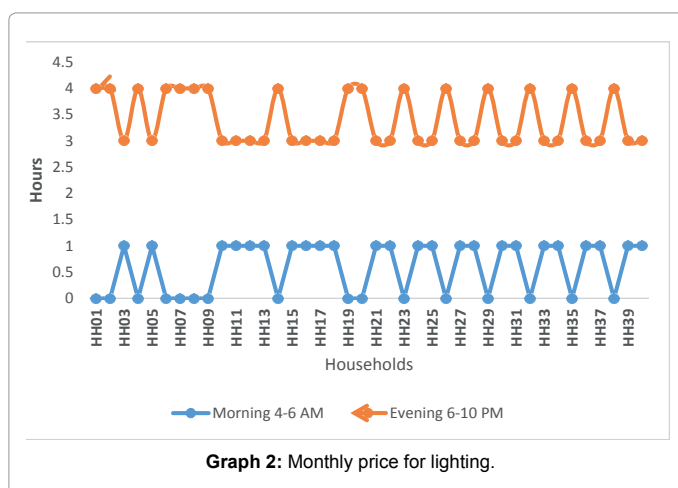
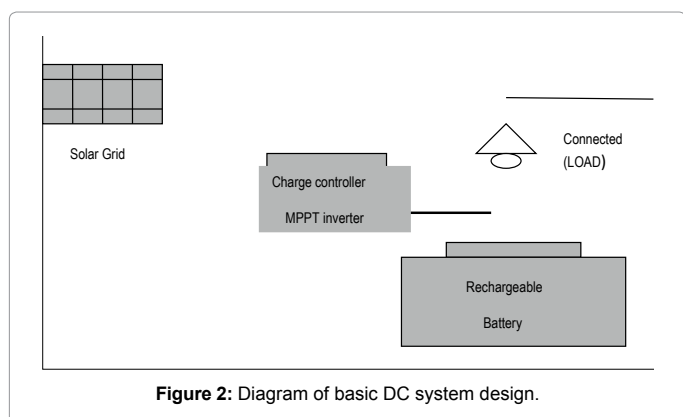
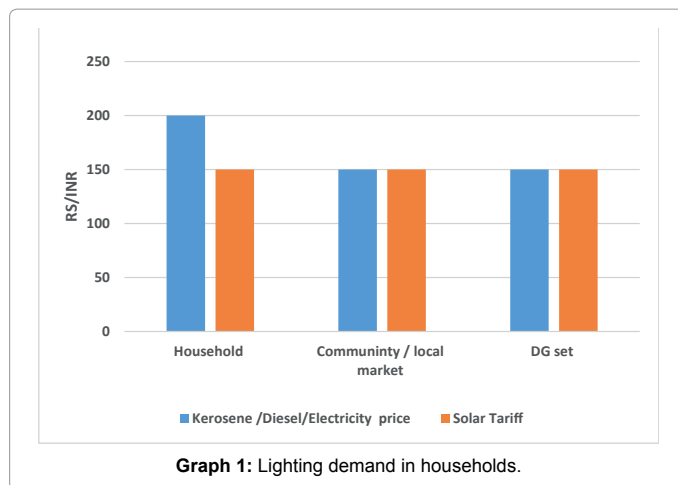
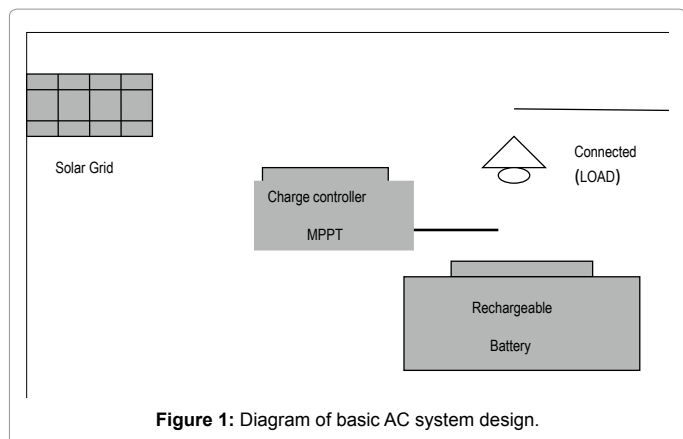

as mobile, lamp, radio etc. Batteries variable play huge role in DC micro grid system better power supply on 24 voltage with copper wiring/cable in distribution line. DC based Solar Micro-grid comparatively easy to install and can be set up by local qualified technicians with some training (Figure 2).

### Lighting Demand and Price in Rural Household/Community

A survey study by TERI 2009, household need 5 hours complete lighting in the rural area morning 4-6 AM and 6-10 PM (Graph 1) according to winter and summer season, this study also compile for the 3- 5 liter kerosene according to household uses the application of kerosene to firing the firewood in the cooking section (UNDP 2003). A comparative study lighting cost of kerosene including the electricity price in (Graph 2). System specification of comparing three lighting system in Table 1 as household needs two numbers of lamp one for cooing and other one of study or rest work and it also replace with solar LED 1W, 2W respectively. And 15-18 CFL lighting sources of diesel replace with 3W solar LED.

### Compression with Decentralized DG SET (Sensitivity Analysis)

Unreliable supply of grid electricity in rural areas that leading to promotion of decentralized Diesel Genset in small rural market. Decentralized DG SET entrepreneur growth increasing to sell electricity to local level. The diesel generator operators in other rural markets have expressed their interest to install DC based solar micro-grids as they believe that the negligible operational cost balances the high investment cost (Table 2).

A real case study case we investigate has the following characteristics. A system of this size would meet the electricity needs of a community 40-100 households/shops for connected sufficient energy to 4 hours peak load. For each case, we estimate the initial and ongoing capital and O & M costs of the equipment. Modules, distribution wires are excluded from this analysis. Solar micro grid System cost break up for 40 households (Table 3) and Diesel genet system cost break up (Table 4 and Table 5).

Using Excel's NPV function, Sensitivity analysis considers the net present value (NPV) of the different options based on the differences in costs and efficiencies discussed above, assumed discount rate (10%) and life span of solar batteries 5 years and solar photovoltaic 20 years (Table 6).

### Solar Micro Grid and Rural Infrastructure

In rural India, technologies for off-grid rural electrification in combination with proper financial balance promises environmentally friendly access to electricity at a lower cost than conventional technologies. This ensures rural users social benefits and improving living standards. At the moment, kerosene and candles are used for lighting in rural areas, while dry cell batteries are used for radio. Both are expensive (1 liter of kerosene cost at least Rs 35 and lasts for one week or about 20 hours) and giving poor quality lighting.

Most of energy users (households and public uses) have an access to grid connections. Though they have access to grid electrification

Sources of Energy	Lamp Number	Watts		lumens (Distance 150 Centimetres at 90°)
Kerosene Household's	2			25-35
Kerosene / Diesel/ Electricity -Community	1	15 -18 W CFL		320
Solar- household's	2	1 W LED	2 W LED	150-240
Solar -Community	1	3 W LED		350

Table 1: Specification of lighting system.

Case	Working Assumption	
Diesel Genset	Annual Inflation	10%
	Working days per month	28
	Tariff per day (Year 1)	5.0
	NPV Discount Rate	10%
	Diesel Cost per litre (INR)	45
Solar Micro-grid	Annual Inflation	10%
	Working days per month	28
	Tariff per day (Year 1)	5.0
	NPV Discount Rate	10%

Table 2: Base-case assumptions.

System Cost Breakup			
Item Description	Multiplier	Per unit cost	Total
Diesel GENSET, 7.5 KVA	1	35,000	35,000
Wiring, Cable, etc.	1	10,000	10,000
Total Capital Cost INR			45,000

Table 3: System cost break up with Diesel genset.

System Cost Breakup			
Item Description	Multiplier	Per unit cost	Total
Solar module 50 Wp	4	5,000	20,000
Solar Battery 12V-100Ah	2	7,500	15,000
Charge Controller Unit 24V, 10 A	1	5,000	5,000
LED Luminary 3 W	40	800	32,000
Cable, Panel Mounting frame, Switches, Misc.	1	15,000	15,000
5 Year AMC charges for power system/ distribution network	1	10,000	10,000
Installation Cost	1	3,000	3,000
Total Capital Cost INR			100,000

Table 4: System cost break up with solar mini grid.

the unreliable supply leaves them in complete darkness and hence compelling them to think of alternatives.

Off-grid electrification can provide an alternative solution for many low demand users at lower cost than grid extension and market growth of rural energy service. Costs of off-grid technologies have decreased significantly over the last few years hence making it affordable for some users. But many still cannot afford it. Taking this fact into account the team has come up with a way to make lighting system accessible to most of the rural households.

In North Uttar Pradesh villages The Energy and Resources Institute facilitate solar micro -grid electrification light solution of 1W and 2W

Capital Cost Breakup		Capital Cost Breakup	
MNRE Subsidy (Rs. /Watt)	150	MNRE Subsidy (Rs. /Watt)	0
System Capacity (Wp)	200	System Capacity (Wp)	200
MNRE subsidy	30,000	MNRE subsidy	-
Self-investment	20,000	Self-investment	20,000
Bank Loan	50,000	Bank Loan	80,000
ANNUAL Rate of interest	12.0%	ANNUAL Rate of interest	12.0%
Payment period (years)	5	Payment period (years)	5
Number of installments	60	Number of installments	60
Monthly EMI	1112	Monthly EMI	1780
Total loan repayment amount INR	66,734	Total loan repayment amount INR	106,774

Table 5: Solar micro grid as considering with subsidy and without subsidy in capital cost break for both options.

Parameters	Diesel genset	Solar micro grid	Solar micro grid with subsidy
Net Cash Flow INR	45000	20000	20000
Net present value INR	407,151	172,334	197718
IRR	92%	50%	80%

Table 6: Net present value of different options.

capacity to rural households for 4 hours daily from 6pm to 10pm when they need the light most. Costing around Rs 150 per month for each household. The project also focused on the commercial users who also need lighting solution the most from 6pm to 10 pm for their business. They charge Rs 6 per day irrespective of the shop being opened or closed.

## Solar Micro Grid Challenge

### Solar panel maintenance

Solar panels require constant cleaning to maximize their utility and life cycle. Productive capacity drops when dust or film accumulates on their surface. Concentrated areas, sustained over a period of time, can lead to failure of an entire segment of a panel. Every panel has a rating factor which indicates its expected readings under healthy conditions. A constant read of the expected value is a strong sign that the panel is functioning well, whereas a sudden dip or a consistently low reading during daytime is a sign of a potential problem. The underlying causes for a dip in the power output of a panel can be one of several: an unclean panel, a faulty battery, poor climate conditions, improper panel orientation.

### Charge controller maintenance

Charge controllers vary from system to system, but they all regulate

current from the panel to the battery until it is fully charged. At that point they either cut power completely or transmit the minimum energy needed to keep the battery topped off.

### Quality of off-grid lighting products

This remains one of the key challenges. Rapid technological advancements and innovations, as well as a multitude of products available at the market, make quality control a difficult task. The consequences of bad quality products are a reputation loss for a whole product range-endangering market development. Located in sparsely populated and remote areas, it has limited accessibility due to bad roads and other factors. The geographical distance between houses in sparsely populated areas increases the cost of maintenance as the connecting wires are more and might get damaged due to storms and trees.

The long-term goal is a rapid scale-up of access to clean, reliable and affordable modern off-grid lighting services. Rural electrification has a number of barriers that are addressed by the training and development of entrepreneurs.

### Training and Development of entrepreneurs

The success of the project lies in the development of entrepreneurs in maintaining the grid and in-house installations. Intensive training program was also developed for the entrepreneurs for product maintenance to the long-term sustainability of the solar market.

### Conclusion

Energy demand, costs, and user satisfaction are particularly interwoven in the case of mini grids, making technology assessment difficult. Mini-grids are sized according to estimated consumption and then can be extended or reevaluated. This problem can be solved at the planning phase by over sizing systems or restriction of consumption per user. Opportunities and challenges were a to find an entrepreneur to invest money; the lengthy procurement process due to a lack of suppliers in the local market; the lengthy legal processes involving in getting a micro-finance and loan guarantee agreement signed with the local bank; and limited awareness of improved lighting products amongst rural residents. Even after developing good rapport with the bank the entrepreneurs were not convinced into taking a loan. Lack of knowledge about the market demand made them skeptical.

### References

1. World energy outlook 2012 global energy trends.

2. International energy agency energy for cooking in developing Countries 2005.
3. REN21 (2011) Renewables 2011: Global Status Report.
4. Panwar NL, Kaushik SC, Kothari S (2011) Kothari Role of renewable energy sources in environmental protection: a review. *Renew Sust Energ Rev* 15: 1513-1524.
5. Ravindranath NH, Hall DO (1995) Biomass, energy, and environment: A developing country perspective from India. Oxford University Press.
6. Reddy AKN, Subramanian DK (1979) The design of rural energy centers. *Proceedings of the Indian Academy of Sciences* 2: 395-416.
7. Chu Y, Meisen P (2011) Review and Comparison of Different Solar Energy Technologies. Global Energy Network Institute (GENI).
8. Chaurey A, Kandpal TC (2010) Assessment and evaluation of SPV based decentralized rural electrification: an overview. *Renew Sust Energ Rev* 14: 2266-2278.
9. UNDP and World Health Organization (WHO) (2009) The energy access situation: a review focusing on the least developing countries and sub-Saharan Africa.
10. Andreas K (2006) Regional disparities in electrification of India do geographic factors matter? Centre for Energy Policy and Economics, Swiss Federal Institute of Technology. CEPE Working Paper No. 51.
11. Bhattacharyya SC (2006) Energy access problem of the poor in India: is rural electrification a remedy. *Energy Policy* 34: 3387-3397.
12. Government of India, Ministry of Power, Annual Report 2009-10.
13. Government of India, census 2011.
14. <http://www.indiaenvironmentportal.org.in/files/file/Energy%20Sources%20of%20Indian%20Households.pdf>
15. Lam NL, Smith KR, Gauthier A, Bates MN (2012) Kerosene: a review of household uses and their hazards in low- and middle-income countries. *J Toxicol Environ Health B Crit Rev* 15: 396-432.
16. Campbell RJ (2012) Weather-Related Power Outages and Electric System Resiliency.
17. Kalogirou SA (2009) Solar energy engineering: processes and systems.
18. Manoj Kumar MV, Banerjee R (2010) Analysis of isolated power systems for village electrification. *Ener Sustain Dev* 14: 213-222.
19. Zahedi A (2011) Review of modelling details in relation to low-concentration solar concentrating photovoltaic. *Renew Sust Energ Rev* 15:1609-1014.
20. Raman P, Murali J, Sakthivadivel D, Vigneswaran VS (2012) Opportunities and challenges in setting up solar photo voltaic based micro grids for electrification in rural areas of India. *Renew Sust Energ Rev* 16: 3320-3325.
21. [http://www.homepower.com/view/?file=HP109\\_pg8\\_TOC](http://www.homepower.com/view/?file=HP109_pg8_TOC)
22. <https://www.esmap.org/sites/esmap.org/files/FR26303India.pdf>
23. TERI (2009) Sustainable Development through - Research, Customization Demonstration of Technology in Jagdishpur Block, district Sultanpur, Uttar Pradesh.