

Acneigenic Stimuli Converge in Phosphoinositol-3 Kinase/ Akt/FoxO1 Signal Transduction

Bodo C. Melnik

Department of Dermatology, Environmental Medicine and Health Theory, University of Osnabrück, Germany

Abstract

The complex multifactorial pathogenesis of acne vulgaris, the most common skin disease, may be explained at the level of genomic regulation. A recent hypothesis suggested that a relative nuclear deficiency of the metabolic sensor and nuclear transcription factor FoxO1 appears to play a key role in the pathogenesis of acne vulgaris. FoxO1 has been identified as an important regulator of androgen receptor, cell proliferation, apoptosis, lipogenesis, oxidative stress regulation, innate and acquired immunity, all important aspects involved in the pathogenesis of acne. It is the intention of this review article to provide further evidence for the potential function of the PI3K/Akt/FoxO1 signaling pathway for other types of acne and acne-like eruptions. Apparently unrelated acneigenic stimuli like hyperglycemic food, insulinotropic milk and dairy product consumption, smoking, psychological stress, fibroblast growth factor receptor-2 mutations in Apert syndrome and acneiform nevus, chloracne, and antidepressant-induced acne are all associated with upregulated PI3K/Akt-signaling known to result in a nuclear deficiency of FoxO1. Reduced nuclear levels of FoxO1 may increase the expression of important acne target genes and derepress nuclear receptors, suggested to be involved in the clinical manifestation of acne. Accumulating indirect evidence supports the role of growth factor- and growth factor-like acneigenic stimuli in posttranslational modification of nuclear FoxO1 and strengthens the hypothesis of a nuclear FoxO1 deficiency as the possible underlying cause of acne vulgaris and clinical acne variants. This review intends to stimulate future research activities on the promising PI3K/Akt/FoxO1 signaling pathway which may be most helpful to unravel the pathogenesis of acne.

Keywords: Acne; Acne variants; Acneigenic stimuli; Phosphoinositol-3 kinase/Akt; FoxO1

The Forkhead Box O1 (FoxO1) Transcription Factor

It is the purpose of this review to support the hypothetical concept that the nuclear transcription factor FoxO1, a member of the class O subfamily of *forkhead box* (FoxO) transcription factors may be involved in the pathogenesis of acne vulgaris and other acne variants. It has been suggested that FoxO1 is the key to understand the relationship between genetic, metabolic and environmental

factors leading to acne [1]. It will be shown that various growth factor- and growth factor-like signals like insulin and insulin-like growth factor-1 (IGF-1) which are perceived by distinct cell membrane receptors are integrated at the level of phosphoinositol-3 kinase (PI3K)/Akt activation (Figure 1). The activated kinase Akt (protein kinase B) translocates into the nucleus where Akt phosphorylates the nuclear FoxO1 protein. Phosphorylated FoxO1 is exported from the nucleus into the cytoplasm thereby derepressing target genes and activating nuclear receptors involved in acne pathogenesis (Figure 1) [1-3].

Nuclear FoxO1 export has an effect on the activity of androgen receptor (AR), peroxisome proliferator-activated receptors (PPARs), liver X receptors (LXRs), the expression of key genes of cell cycle control (cyclin D1, D2, p21, p27), matrix modulation by matrix metalloproteinases (MMPs), the promoter activity of sterol regulatory element binding proteins (SREBPs) as the most important transcription factors of lipogenesis, the insulin sensitivity regulating glucose transporter protein-4 (GLUT4), the innate and acquired immune responses regulating antimicrobial peptide synthesis, toll-like receptor-2 (TLR2) expression and T cell proliferation. It has also been demonstrated that retinoids are potent inducers of FoxO proteins, and FoxO1 mediates retinoid-induced adverse effects like isotretinoin-induced hypertriglyceridemia [1]. The similar clinical appearance of acne vulgaris and acne variants and isotretinoin's mode of action on all pathogenical aspects of acne implies the existence of

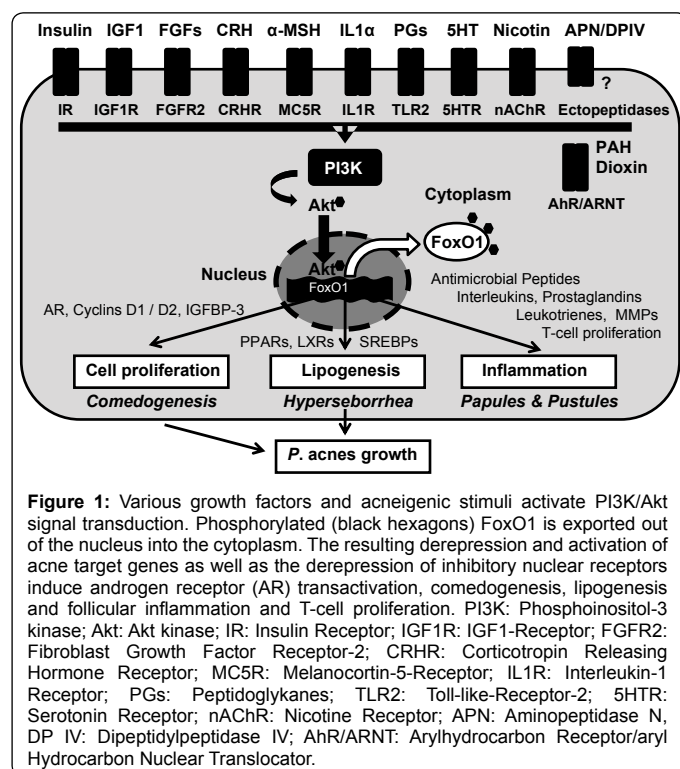

Figure 1: Various growth factors and acneigenic stimuli activate PI3K/Akt signal transduction. Phosphorylated (black hexagons) FoxO1 is exported out of the nucleus into the cytoplasm. The resulting derepression and activation of acne target genes as well as the derepression of inhibitory nuclear receptors induce androgen receptor (AR) transactivation, comedogenesis, lipogenesis and follicular inflammation and T-cell proliferation. PI3K: Phosphoinositol-3 kinase; Akt: Akt kinase; IR: Insulin Receptor; IGF1R: IGF1-Receptor; FGFR2: Fibroblast Growth Factor Receptor-2; CRHR: Corticotropin Releasing Hormone Receptor; MC5R: Melanocortin-5-Receptor; IL1R: Interleukin-1 Receptor; PGs: Peptidoglykanes; TLR2: Toll-like-Receptor-2; 5HTR: Serotonin Receptor; nAChR: Nicotine Receptor; APN: Aminopeptidase N, DP IV: Dipeptidylpeptidase IV; AhR/ARNT: Arylhydrocarbon Receptor/aryl Hydrocarbon Nuclear Translocator.

Corresponding author: Bodo C. Melnik, Eickhoffstrasse 20, D-33330 Gütersloh, Germany, E-mail: melnik@t-online.de

Received July 27, 2010; **Accepted** September 13, 2010; **Published** September 13, 2010

Citation: Melnik BC (2010) Acneigenic Stimuli Converge in Phosphoinositol-3 Kinase/Akt/FoxO1 Signal Transduction. J Clin Exp Dermatol Res 1:101. doi:10.4172/2155-9554.1000101

Copyright: © 2010 Melnik BC. This is an open-access article distributed under the terms of the Creative Commons Attribution License, which permits unrestricted use, distribution, and reproduction in any medium, provided the original author and source are credited.



a common signaling pathway. In this paper, the effect of acneigenic stimuli on the PI3K/Akt/FoxO1 signal transduction pathway and its contribution to the pathogenesis of clinical acne variants is dissected in further detail.

The Impact of Nutrition on the Metabolic Sensor FoxO1

FoxO1 and aggravation of acne by milk consumption

After nearly half a century, the role of diet in the pathogenesis of acne has regained recent scientific interest [4-10]. Western diet has been associated with a high prevalence of acne [4-10]. Western life style nutrition in industrialized countries is associated with increased insulin/IGF-1 signaling, which is superimposed on the physiological growth factor signaling of puberty, a mechanism which may well explain the high and increasing prevalence of acne in industrialized countries. Milk consumption induces high serum levels of IGF-1 [11-15]. Milk consumption has been associated with linear growth and the manifestation of acne [16-18]. It is the biologic principle of milk to promote growth by increased insulin/IGF-1 signaling and induction of insulin resistance [11,12,15,19-23]. The relation between milk-induced insulin/IGF-1 signaling and the pathogenesis of acne and chronic diseases of Western civilization has recently been presented [7,10,24-27]. The insulinotropic effect of milk resides within the hydrophilic whey protein fraction [28]. Both insulin and IGF-1 reduce nuclear levels of FoxO1 [2,3].

FoxO1 and aggravation of acne by hyperglycemic carbohydrates

Nutrients rich in carbohydrates with a high glycemic index (GI) induce hyperglycemia, reactive hyperinsulinemia, and increased IGF-1 serum levels. In contrast, a diet with a low glycemic load decreased serum IGF-1 levels and significantly improved acne following a 12-week diet [29]. A diet with a low glycemic load versus a diet with a high glycemic load in 12 male acne patients showed a significant increase of IGF binding protein-1 (IGFBP-1) and IGFBP-3 in the low glycemic load group, suggesting that a diet with a low glycemic load reduces free IGF-1 activity and bioavailability [30]. Intriguingly, the genes of IGFBP-1 and IGFBP-3 are FoxO-controlled [3]. Improvement of acne has also been reported during the carbohydrate-restricted South Beach Florida diet [31,32]. A population-based cross-sectional study in Oslo of 3775 late adolescents (age 18 and 19 years) revealed a statistically significant association between acne and frequent consumption of chocolate, sweets and potato chips [33]. Restriction of carbohydrates and consumption of carbohydrates with a low GI will reduce insulin secretion of pancreatic β -cells and lowers basal insulin levels thereby improving the nuclear content of the nutritional sensor and transcription factor FoxO1.

FoxO1 and acne-related endocrine disorders

The polycystic ovary syndrome (PCOS) is a common endocrine disorder affecting 5-20 % of women depending on their ethnic background [34]. Hyperandrogenemia, altered gonadotropin secretion as well as insulin resistance are involved in the pathogenesis of PCOS. PCOS is frequently associated with acne and hirsutism. Insulin resistance of adipose tissue and muscle in PCOS leads to increased insulin/IGF-1 signaling to epithelial targets like the pilosebaceous units which are not insulin resistant [34-36]. Other endocrine disorders with increased levels of insulin and/or IGF-1 and insulin resistance are often associated with acne like HAIR-AN (hyperandrogenism, insulin resistance, acanthosis nigricans) syndrome [37]. An increased incidence of acne is observed in acromegaly [38], Laron syndrome overdosed with recombinant IGF-

1 [39,40], premature adrenarche and precocious pubarche [41-44]. All these endocrine disorders with increased insulin/IGF-1 levels are expected to be associated with reduced nuclear concentrations of FoxO1, thus promoting the development of acne.

FoxO1 and smoker's acne

Recent evidence supports the association between smoking and persistence of postpubertal acne [45,46]. There is evidence that smokers are insulin resistant and hyperinsulinemic, as compared with non-smokers [47]. Hyperinsulinemia, dyslipidemia and exaggerated adrenal androgen response to ACTH have been observed in male smokers [48]. Smoking is associated with increased free testosterone and fasting insulin levels in women with PCOS, resulting in aggravated insulin resistance [49]. Thus, smoking is associated with increased insulin/PI3K/Akt signaling of the pilosebaceous unit which may drive FoxO1 out of the nucleus.

Nicotine binds to acetylcholine receptors (AChRs). Undifferentiated sebocytes expressed $\alpha 3$, $\alpha 9$, $\beta 4$, m3-m5 AChRs, whereas $\alpha 7$, $\beta 2$, $\beta 4$, m2, and m4 were found in mature sebocytes [50]. Presence of AChRs and nicotinic activity are also found in the infundibulum of the pilosebaceous unit and can promote infundibular epithelial hyperplasia and follicular plugging, suggesting an important role for the cholinergic system in acne vulgaris and acne inversa (hidradenitis suppurativa) [51]. Activation of Akt in human airway epithelial cells by nicotine and a tobacco-specific carcinogen (NNK) has been shown [52]. Activation of Akt by nicotine or NNK occurred within minutes at concentrations achievable by smokers and depended upon $\alpha 3$ -/ $\alpha 4$ -containing or $\alpha 7$ -containing nicotinic AChRs, respectively [52]. In neuronal cells, $\alpha 7$ nicotinic AChRs have been shown to activate the PI3K/Akt pathway [53]. A time-dependent increase in phosphorylated Akt in oral keratinocytes and other epithelial cell lines has been observed with 100 μ M nicotine treatment [54]. Thus, insulin, nicotine and other components of tobacco smoke may converge in the activation of the PI3K/Akt pathway as demonstrated in various cell systems. Activation of PI3K/Akt by smoking acts like growth factor signaling which most likely reduces the nuclear content of FoxO1.

FoxO1 and stress-induced acne

The sebaceous gland is not only a passive endocrine target organ that reacts to sex hormones but also plays an active part of various neuroendocrine/ neuromediator axes involving corticotropin releasing hormone (CRH) and melanocortin peptides [55,56].

Most growth factors signal via tyrosine kinase receptors which activate the PI3K/Akt pathway. A further mechanism of PI3K activation by G-protein coupled receptors (GPCRs) involves a direct binding of G $\beta\gamma$ subunits and the GTPase Ras [57]. The human sebaceous gland has been shown to express GPCRs for neuropeptides, such as CRH and melanocortins, β -endorphin, vasoactive intestinal polypeptide, NP Y and calcitonin gene-related peptide. These receptors modulate the production of inflammatory cytokines, proliferation, differentiation, lipogenesis and androgen metabolism in human sebocytes [58-61].

The hypothalamic-pituitary-adrenal (HPA) axis mediates neuroendocrine responses of sebaceous glands to stress [62]. CRH is the principal neuroregulator of the HPA-axis and plays an important role in coordinating the endocrine, autonomic and immune responses to stress [63]. The presence of CRH and its receptors CRHR1 and CRHR2 have been demonstrated in human sebaceous glands and SZ95 sebocytes [60,64-66]. CRH can induce synthesis of neutral lipids in SZ95 sebocytes, whereas antalarmin, a CRHR1 specific inhibitor,



reduced sebaceous neutral lipid synthesis [66]. A significant increase in CRHR expression has been observed in sebaceous glands in acne-involved skin compared with sebaceous glands not involved with acne [60]. Thus, substantial evidence points to the important role of CRH/CRHR signaling in the induction of lipogenesis and inflammation in acne [67]. In human monocytic cells, CRH has been demonstrated to activate the PI3K/Akt pathway [68]. These data imply that acneigenic effects of stress might reduce nuclear levels of FoxO1 via CRH/CRHR-induced upregulation of PI3K/Akt in sebaceous glands (Figure 1).

The proopiomelanocortin system also plays an important role as a neuromediator system in controlling the sebaceous gland. The α -melanocyte-stimulating hormone (α -MSH) can stimulate sebocyte differentiation and lipogenesis [69,70]. Human sebocytes express melanocortin-1 receptor (MC1R) and MC5R [67,71,72]. MC1R was expressed in both undifferentiated and differentiated sebocytes. In acne-involved sebaceous glands a higher expression of MC1R could be detected in comparison with sebocytes of normal skin [73].

MC5R, only expressed in differentiated sebocytes and apparently stimulates lipogenesis [72]. MC5R function also seems to be related to stress response. Upregulation of MC5R was detected in the rat adrenal cortex as a consequence of a chronic stress [74]. MC5R has a preferential affinity for α -MSH, followed by ACTH and β -MSH [75]. By this mechanism stress-induced ACTH release may stimulate sebaceous glands via MC5R. Targeted deletion of MC5R resulted in deficient secretion of sebaceous glands [76]. MC5R stimulation by α -MSH induced a 10- or 16-fold rise of cAMP levels and activated ERK1/2 which was abolished by PI3K inhibitor. These data demonstrate that MC5R signals through a PI3K-regulated pathway [77]. In analogy to other GPCR-signals, MC5R-mediate activation of the PI3K/Akt pathway may contribute to further downregulation of the nuclear content of FoxO1, thereby promoting sebaceous lipogenesis.

FoxO1 and ectopeptidase inhibitor-mediated effects on acne and immune function

Ectopeptidases are important functional transmembrane proteins which are able to modulate bioactive peptide responses and influence growth, apoptosis and differentiation, as well as adhesion and motility of cells [78]. Ectopeptidase-mediated signal transduction frequently involves tyrosine phosphorylation [78]. Ectopeptidases possess a short intracytoplasmic domain with no obvious motifs [78]. Recently, the ectopeptidases dipeptidylpeptidase IV (DP IV) and aminopeptidase N (APN) have been associated with the initiation of acne [79]. It could be demonstrated that inhibitors of DP IV and APN have potent immunosuppressive and anti-inflammatory effects in various disease models [79]. Interleukin-1 (IL-1) is a known cytokine involved in the initiation of acne [80]. Intriguingly, inhibitors of DP IV and APN have been demonstrated to stimulate the expression of IL-1 receptor antagonist which may counteract the acne-promoting effect of IL-1 [79]. In SZ95 sebocytes, DP IV- and APN-inhibitors suppressed proliferation, enhanced terminal differentiation and slightly decreased total neutral lipid production [79]. Thus, inhibitors of DP IV and APN may be able to reduce comedogenesis, lipogenesis and inflammation [79].

It has recently been shown in *Drosophila* that the induction of antimicrobial peptides (AMPs) can be achieved independently of toll-like receptor (TLR) pathways by FoxO-dependent gene regulation [81]. AMP genes are activated in response to nuclear FoxO activity [81]. Increased growth factor signaling of puberty and insulinotropic Western diet may reduce nuclear levels of FoxO1 and AMP activity thus promoting *P. acnes* growth and biofilm formation. *P. acnes*-

mediated TLR2-stimulation may then initiate T-cell infiltration as observed in early acne lesions [80]. Indeed, around uninvolved follicles of early acne lesions large numbers of CD4+ T cells over and above the constitutive level of surveillance T cells in normal skin have been detected. Within the CD4+ T cell population, the majority were memory/effector, with a similar proportion exhibiting a skin homing phenotype suggesting the start of a specific inflammatory response from the adaptive immune system [80].

DP IV and DP IV-like enzymes, such as dipeptidyl peptidase II, dipeptidyl peptidase VIII, and dipeptidyl peptidase IX, have been recognized to regulate T lymphocyte activation [82,83], whereas DP IV- and APN-inhibitors suppressed proliferation of *P. acnes*-stimulated T cells *ex vivo* and induced an anti-inflammatory cytokine profile [84]. Remarkably, FoxO1 plays not only a role in the regulation of innate immunity but is of great importance in the regulation of T-cell function and T-cell homeostasis [85]. In resting T-cells, FoxO proteins reside in the nucleus. Akt activation via the stimulation of the T-cell receptor (TcR), CD28, and cytokine signaling pathways inactivates nuclear FoxO proteins which is associated with the induction of T cell proliferation [85-87]. Indeed, ectopic expression of an Akt-insensitive FoxO1 mutant suppresses T-cell proliferation, suggesting that inactivation of FoxO1, i.e. nuclear extrusion of FoxO1, is an obligatory step for T-cells to enter the cell cycle [87].

An interaction between DP IV and IGF-2 receptor (IGF2R)-mediated T-cell activation has been described [88]. Internalization of DP IV is associated with cross-linking with IGF2R. In T-cells, triggering of DP IV by antibody is associated with calcium mobilization and activation of cellular proteins involved in TcR/CD3-mediated signal transduction [89]. At present, the mechanisms of growth factor-like signaling of ectopeptidases is not completely understood but the enzymatic activity of APN and DP IV does not appear to be essential for signal transduction [89,90]. Anti-CD3-mediated activation of human lymphocytes increased the expression of Akt. Akt activation could significantly be suppressed by a DP IV inhibitor [91]. Thus, ectopeptidase inhibitor treatment may have beneficial anti-inflammatory effects on acne by downregulation of IL-1 signaling as well as downregulation of Akt-mediated T-cell proliferation by rising the nuclear levels of FoxO1 in T-cells [85,92].

FoxO1 and acne in Apert syndrome and acneiform nevus

Severe acne of early onset is a hallmark of Apert syndrome, a rare craniosynostosis syndrome [93]. Apert syndrome is associated with a gain-of-function mutation (either Ser252Trp or Pro253Arg) of fibroblast growth factor receptor-2 (FGFR2) [94-96]. Epidermal mosaicism producing an acneiform nevus has been observed in two boys exhibiting a somatic mutation of FGFR2 with a Ser252Trp substitution within the acneiform nevus [97,98].

FGFR2, another important tyrosine kinase receptor involved in growth factor signaling, plays an important role in the regulation of pilosebaceous homeostasis and appears to be involved in the pathogenesis of acne [99,100]. Androgen-mediated mesenchymal-epithelial signaling to keratinocytes and sebocytes is a fundamental process for development and homeostasis of the pilosebaceous unit and involves AR-dependent FGF/FGFR2 signaling [99,100]. Anti-acne agents have been suggested to attenuate FGFR2 signal transduction in acne [101].

Remarkably, activated FGFRs significantly contribute to PI3K/Akt signaling [102]. The mutant FGFR2s of Apert syndrome exhibited a markedly upregulated downstream signaling compared to normal



FGFR2 [103]. Delayed endocytosis and proteasomal degradation of the mutant FGFR2s appear to be the cause of increased downstream signal transduction including elevated PI3K/Akt activity [103]. The gain-of-function mutations of FGFR2 with increased PI3K/Akt activity might reduce the nuclear level of FoxO1, thus explaining the development of acne in Apert syndrome and acneiform nevus. Consistent with these data is the observation that acne in Apert syndrome and acneiform nevus is responsive to oral isotretinoin treatment [98,104-106]. Isotretinoin-induced upregulation of decreased nuclear FoxO1 levels would compensate for the signaling defect of the FGFR2 gain-of-function mutations. Thus, Apert syndrome and acneiform nevus are two acne model diseases with increased growth factor signaling which result in PI3K/Akt activation with decreased nuclear levels of FoxO1.

FoxO1 and chloracne

Environmental pollutants can result in a variant of acne called chloracne by systemic exposure to certain halogenated aromatic hydrocarbons [107]. Chloracne is clinically characterized by a multitude of acne-like eruption of comedones, pustules and later on cysts, and squamous metaplasia of epithelial cells within the duct of the sebaceous gland [108]. Chloracne is regarded as a reliable indicator of dioxin exposure and is a persistent process that remains years after exposure [109,110]. The most biologically active isomer is 2,3,7,8-tetra-chlorodibenzo-*p*-dioxin (TCDD).

The pleiotropic effects caused by dioxins are mediated by the aryl hydrocarbon receptor (AhR), which is a ligand-activated transcription factor essential for inducing a battery of xenobiotic metabolizing enzymes [111]. AhR is considered to play not only a role in the regulation of xenobiotic metabolism but also in the regulation of growth and differentiation [112]. The binding of dioxins to AhR leads to receptor dimerization with aryl hydrocarbon nuclear translocator (ARNT) followed by subsequent binding of this heterodimer to the dioxin response elements located in the promoter region of certain genes. The high level of AhR expression in epidermis, the finding that AhR was expressed in epidermal keratinocytes in a differentiation-associated manner and the essential role of many AhR/ARNT-dependent genes in the maintenance of skin homeostasis supported the possible involvement of AhR/ARNT signaling in chloracne pathogenesis [113-116].

Benzo[a]pyrene (BaP) and TCDD modulate signal transduction pathways in various cells. BaP produced a mitogenic signal in human mammary epithelial cells. Both BaP and TCDD activated IGF-1 signaling pathways in a human mammary epithelial cell line under insulin-deficient conditions [117]. Increased signaling through IGF1R activated PI3K [117]. In contrast, the PI3K inhibitor LY294002 was found to inhibit the growth-promoting effects of TCDD seen under insulin-deficient conditions. Thus, aromatic hydrocarbons like TCDD and BaP activate IGF1R signaling and increase the activity of PI3K which will reduce nuclear concentrations of FoxO1, a mechanism most likely involved in the pathogenesis of chloracne.

BaP is a component found in tobacco smoke and tar and has been shown to activate Akt in osteoblasts [118]. Activation of the PI3K/Akt oncogenic pathway is known to inhibit apoptosis. In a mammary epithelial cell line, TCDD stimulated PI3K and inhibited growth factor withdrawal-induced apoptosis [119]. Intriguingly, ozone, one of the main components of photochemical smog of urban environment, has been shown to activate the PI3K in epidermal keratinocytes [120]. Thus, PI3K/Akt activation by environmental acneogens like polyaromatic hydrocarbons and ozone might be involved in the

pathogenesis of tar acne, smoker's acne, pollutant-induced acne and chloracne.

FoxO1, antidepressant-induced acne and isotretinoin-induced depression

Severe acne and acneiform eruptions have been observed with high doses of tricyclic antidepressants like amineptine and lithium therapy [121-124]. In brain of mice, lithium significantly decreased the transcriptional activity and protein levels of FoxO3 [125], the most important activator of the FoxO1 promoter [126]. In mice, elevated serotonergic activity due to D-fenfluramine administration increased PI3K/Akt-mediated phosphorylation of FoxO1 and FoxO3a in various regions of the brain resulting in nuclear deficiency of FoxO1 and FoxO3a content [127]. Long-term treatment with imipramine increased phosphorylation of FoxO1 and FoxO3 as well [127]. FoxOs in neuronal cells of rodents have been shown to be of functional importance in the regulation of behavioral manifestation [127,128]. Various cells of the skin express functionally active membrane-bound receptors for serotonin (5-hydroxytryptamine) [129]. It has been observed that ligand binding to serotonin receptors resulted in Akt activation [130-133]. Upregulated serotonin levels by antidepressants reduce nuclear concentrations of FoxO1 and FoxO3 in neuronal cells, mechanisms which appears to be associated with improved mood and reduced anxiety. Indeed, FoxO3-deficient mice presented with a significant anti-depressant-like behavior [127]. A nuclear increase of FoxO1 by oral isotretinoin treatment could be associated with mood disturbances and depression reported during isotretinoin therapy [134].

Modification of serotonin receptor signaling by antidepressants might thus be associated with PI3K/Akt activation and reduced nuclear levels of FoxO1 which may mediate antidepressant-induced acne.

Conclusion

All major factors in acne pathogenesis, i.e., AR-mediated signal transduction, increased proliferation of keratinocytes, augmented lipogenesis, upregulation of TLR2 signaling with local activation of innate and adaptive immune responses has been linked to a nuclear deficiency of FoxO1 [1]. By means of translational medicine, all studied acneigenic stimuli and their receptor-mediated signal transductions appear to converge at the integration level of PI3K/Akt. The net activation of PI3K/Akt could finally determine the nuclear content of FoxO1 and its gene regulatory impact. Acneigenic stimuli which have to be regarded as growth factor- or growth factor-like signals appear to focus on a common convergence point, the nuclear content of transcription factor FoxO1.

The hypothetical concept of a nuclear FoxO1 deficiency in acne vulgaris and related acne variants for the first time offers a unified explanation for the acne-aggravating consumption of insulinotropic dairy products, carbohydrates with high GI, acne-promoting effects of smoking, psychological stress, acneigenic effects of polyaromatic hydrocarbons, the effect of mutant FGFR2s in Apert syndrome and acneiform nevus and IL-1 α -induced acne in PAPA syndrome. Furthermore, the presented hypothesis sheds a new light on the therapeutic and adverse effects of oral isotretinoin. Increased nuclear FoxO1 concentrations by systemic isotretinoin treatment have been proposed as isotretinoin's major mode of action (Figure 2) [135].

The presented hypothesis offers new therapeutic and dietary treatment strategies for acne. These include especially the reduction



of insulinotropic and IGF-1 rising dairy products, the restriction of carbohydrates with high GI, cessation of smoking, avoidance of occupational exposition with acneigenic polyaromatic hydrocarbons, the consideration of drug-induced imbalances of nuclear content of FoxO1 and the control of psychological stress factors. As most of these factors are associated with Western life style [24-26], acne could be regarded as a condition with up-regulated growth factor signaling primarily due to environmental effectors. Various apparently unrelated acneigenic stimuli either environmental (smoking, aromatic hydrocarbons, ozone), dietary (hyperglycemic carbohydrates and hyperinsulinotropic milk and dairy products), drug-induced (antidepressants, lithium) or genetic (FGFR2-mutations, AR polymorphism with short N-terminal CAG repeats) appear to be integrated at the level of PI3K/Akt activation. These promote the nuclear extrusion of the transcription factor FoxO1. Thus, evidence from translational medicine supports the potential function of the PI3K/Akt/FoxO1 signaling pathway in acne and its variants. Future studies in acne research should focus on growth factor signaling, especially on the role of nutrigenomic regulation of insulinotropic Western diet, to understand acne pathogenesis at the level of gene regulation and the precise role of FoxO transcription factors in the clinical manifestation of the most common skin disease of industrialized countries (Table 1).

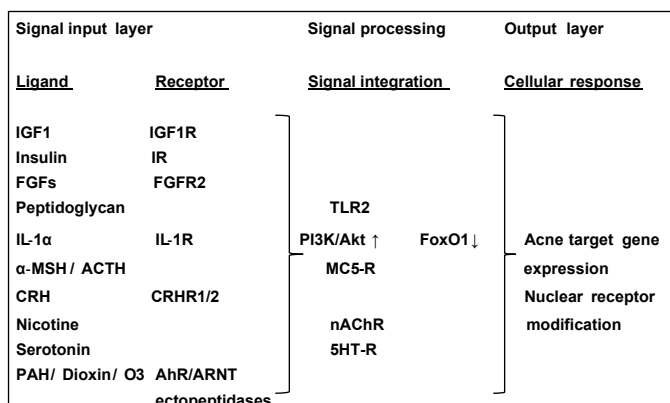

Figure 2: Acneigenic growth factor signaling integrated at PI3K/Akt/FoxO1.

Competing interests

The author declares that he has no competing interest.

References

- Melnik BC (2010) FoxO1- the key for the pathogenesis and therapy of acne? J Dtsch Dermatol Ges 8: 105-113.
- Huang H, Tindall DJ (2007) Dynamic FoxO transcription factors. J Cell Sci 120: 2479-2487.
- Van der Heide LP, Hoekman MF, Smid MP (2004) The ins and outs of FoxO shuttling: mechanisms of FoxO translocation and transcriptional regulation. Biochem J 380: 297-309.
- Cordain L, Lindeberg S, Hurtado M, Hill K, Eaton SB, et al. (2002) Acne vulgaris: A disease of Western civilization. Arch Dermatol 138: 1584-1590.
- Cordain L (2005) Implications for the role of diet in acne. Semin Cutan Med Surg 24: 84-91.
- Danby FW (2008) Diet and acne. Clin Dermatol 26: 93-96.
- Spencer EH, Ferdowsian HR, Barnard ND (2009) Diet and acne: a review of the evidence. Int J Dermatol 48: 339-347.
- Melnik B (2010) Acne vulgaris: role of diet. Hautarzt 61: 115-125.
- Pappas A (2009) The relationship of diet and acne. A review. Dermatoendocrinol 1: 1-6.
- Bowe WP, Joshi SS, Shalita AR (2010) Diet and acne. J Am Acad Dermatol 63: 124-141.
- Hoppe C, Mølgaard C, Vaag A, Barkholt V, Michaelsen KF (2005) High intakes of milk, but not meat, increase s-insulin and insulin resistance in 8-year-old boys. Eur J Clin Nutr 59: 393-398.
- Esterle L, Sabatier JP, Guillon-Metz F, Walrant-Debray O, Guaydier-Souquières G, et al. (2009) Milk, rather than other foods, is associated with vertebral bone mass and circulating IGF-1 in female adolescents. Osteoporos Int 20: 567-575.
- Norat T, Dossus L, Rinaldi S, Overvad K, Grønbaek H, et al. (2007) Diet, serum insulin-like growth factor-I and IGF-binding protein-3 in European women. Eur J Clin Nutr 61: 91-98.
- Crowe FL, Key TJ, Allen NE, Appleby PN, Roddam A et al. (2009) The association between diet and serum concentrations of IGF-I, IGFBP-1, IGFBP-2, and IGFBP-3 in the European Prospective Investigation into Cancer and Nutrition. Cancer Epidemiol Biomarkers Prev 18: 1333-1340.
- Rich-Edwards JW, Ganmaa D, Pollak MN, Nakamoto EK, Kleinman K, et al. (2007) Milk consumption and the prepubertal somatotrophic axis. Nutr J 6: 28.
- Hoppe C, Molgaard C, Michaelsen KF (2006) Cow's milk and linear growth in industrialized and developing countries. Ann Rev Nutr 26: 131-173.

Research target	Research question	Predicted results
Sebocyte	Regulatory role of FoxO1 in sebaceous lipogenesis; FoxO1-mediated co-regulation of androgen receptor, PPARγ, LXR, RAR, RXR; mechanism of isotretinoin-induced sebocyte apoptosis	Decreased levels of nuclear FoxO1 in sebocytes in acne may stimulate sebaceous lipogenesis; isotretinoin may induce sebocyte apoptosis by upregulation of nuclear FoxO1 and FoxO1-dependent apoptosis genes like IGFBP-3 and neutrophil gelatinase-associated lipocalin
Keratinocyte	Investigation of the role of FoxO1 in keratinocyte proliferation in the pilosebaceous unit (PSU)	Decreased nuclear levels of FoxO1 in acro-infundibular keratinocytes in acne may be associated with decreased cyclin D1, D2 and increased p21 and p27
Oxidative stress	Clarification of the role of FoxO1 in oxidative stress responses of the PSU; antioxidative mechanisms of isotretinoin action	Downregulated nuclear FoxO1 in acne may result in increased oxidative stress with suppressed expression of FoxO1-regulated catalase and superoxide dismutase
Innate immunity	Role of FoxO1 in the regulation of innate immunity of the PSU	Downregulated nuclear FoxO1 in acne may decrease local innate immunity of the sebaceous follicle allowing <i>P. acnes</i> overgrowth and biofilm formation
Acquired immunity	Influence of FoxO1 in T-cell regulation of the PSU; Influence of isotretinoin on FoxO1-mediated T-cell regulation	Reduced levels of nuclear FoxO1 in T-cells in PSU of acne patients; anti-inflammatory effect of isotretinoin or ectopeptidase inhibitors by upregulation of nuclear FoxO1 in T-cells
Dermal response	Role of FoxO1 in matrix metalloproteinase (MMP) regulation and dermal remodeling	Downregulated nuclear FoxO1 in acne may increase the activity of MMPs promoting increased dermal tissue destruction
Mode of retinoid action Adverse drug effects of isotretinoin	Clarification of the role of FoxO1 in isotretinoin's mode of action; Role of retinoids in FoxO-regulation; isotretinoin-induced hypertriglyceridemia, FoxO-1-mediated impairment of glucose metabolism, role of FoxOs in neurological adverse effects of isotretinoin	Isotretinoin's primary mode of action appears to be an increase of nuclear levels of FoxO1; high levels of nuclear FoxO1 may be associated with increased hepatic VLDL secretion, decreased apo-CIII-mediated VLDL hydrolysis by apo-CIII-dependent lipoprotein lipase, increased hepatic gluconeogenesis and increased neuronal levels of nuclear FoxO1 with neurological alterations (mood disturbances)

Table 1: Proposed FoxO1-related topics for future acne research.

17. Adebamowo CA, Spiegelman D, Berkey CS, Danby FW, Rockett HH, et al. (2006) Milk consumption and acne in adolescent girls. *Dermatology Online J* 12: 1-12.
18. Adebamowo CA, Spiegelman D, Berkey CS, Danby FW, Rockett HH, et al. (2008) Milk consumption and acne in teenaged boys. *J Am Acad Dermatol* 58: 787-793.
19. Hoppe C, Udam TR, Lauritzen L, Mølgaard C, Juul A, et al. (2004) Animal protein intake, serum insulin-like growth factor I, and growth in healthy 2.5-y-old Danish children. *Am J Clin Nutr* 80: 447-452.
20. Hoppe C, Mølgaard C, Juul A, Michaelsen KF (2004) High intakes of skimmed milk, but not meat increase serum IGF-I and IGFBP-3 in eight-year-old boys. *Eur J Clin Nutr* 58: 1211-1216.
21. Östman EM, Lijeborg Elmstahl HGM, Björck IME (2001) Inconsistency between glycemic and insulinemic responses to regular and fermented milk products. *Am J Clin Nutr* 74: 96-100.
22. Hoyt G, Hickey MS, Cordain L (2005) Dissociation of the glycaemic and insulinaemic responses to whole and skimmed milk. *Br J Nutr* 93: 175-177.
23. Qin LQ, Ka HE, Xu JY (2009) Milk consumption and circulating insulin-like growth factor-I level: a systematic literature review. *Intern J Food Sci Nutr* 7: 330-340.
24. Melnik B (2009) Milk consumption: aggravating factor of acne and promoter of chronic diseases of Western societies. *J Dtsch Dermatol Ges* 7: 364-370.
25. Melnik BC, Schmitz G (2009) Role of insulin, insulin-like growth factor-1, hyperglycaemic food and milk consumption in the pathogenesis of acne vulgaris. *Exp Dermatol* 18: 833-841.
26. Melnik BC (2009) Milk – the promoter of chronic Western diseases. *Med Hypotheses* 72: 631-639.
27. Melnik BC (2009) Permanent impairment of insulin resistance from pregnancy to adulthood: The primary basic risk factor of chronic Western diseases. *Med Hypotheses* 73: 670-681.
28. Hoppe C, Mølgaard C, Dalum C, Vaag A, Michaelsen KF (2009) Differential effects of casein versus whey on fasting plasma levels of insulin, IGF-1 and IGF-1/IGFBP-3: results from a randomized 7-day supplementation study in prepubertal boys. *Eur J Clin Nutr* 63: 1076-1083.
29. Smith RN, Mann NJ, Braue A, Mäkeläinen H, Varigos GA (2007) The effect of a high protein, low glycemic load diet versus a conventional, high glycemic load diet on biochemical parameters associated with acne vulgaris: a randomized, investigator-masked, controlled trial. *J Am Acad Dermatol* 57:247-256.
30. Smith RN, Mann NJ, Braue A, Mäkeläinen H, Varigos GA (2008) A pilot study to determine the short-term effects of a low glycemic load diet on hormonal markers of acne: a nonrandomized, parallel, controlled feeding trial. *Mol Nutr Food Res* 52: 718-726.
31. Hayes MR, Miller CK, Ulbrecht JS, Mauger JL, Parker-Klees L, et al. (2007) A carbohydrate-restricted diet alters gut peptides and adiposity signals in men and women with metabolic syndrome. *J Nutr* 137: 1944-1950.
32. Rouhani P, Berman B, Rouhani G (2009) Acne improves with a popular, low glycemic diet from South Beach. *J Am Acad Dermatol* 60: AB14.
33. Halvorsen JA, Dalgard F, Thoresen M, Bjertness E, Lien L (2009) Is the association between acne and mental distress influenced by diet? Results from a cross-sectional population study among 3775 late adolescents in Oslo, Norway. *BMC Public Health* 9: 340.
34. Norman RJ, Dewailly D, Legro RS, Hickey TE (2007) Polycystic ovary syndrome. *Lancet* 370: 685-697.
35. Thierry van Dessel HJ, Lee PD, Faessen G, Fauser BC, Giudice LC (1999) Elevated serum levels of free insulin-like growth factor I in polycystic ovary syndrome. *J Clin Endocrinol Metabol* 84: 3030-3035.
36. Corbould A (2008) Insulin resistance in skeletal muscle and adipose tissue in polycystic ovary syndrome: are the molecular mechanisms distinct from type 2 diabetes? *Panminerva Med* 50: 279-294.
37. Vigouroux C (2010) What have we learned from monogenic forms of severe insulin resistance associated with PCOS/HAIRAN? *Ann Endocrinol* 71: 222-224.
38. Burton JL, Libman LJ, Cunliffe WJ, Wilkinson R, Hall R, et al. (1972) Sebum excretion in acromegaly. *Br Med J* 1: 406-408.
39. Rosenbloom AL (2007) The role of recombinant insulin-like growth factor I in the treatment of the short child. *Curr Opin Pediatr* 19: 458-464.
40. Klinger B, Anin S, Silbergeld A, Eshet R, Laron Z (1998) Development of hyperandrogenism during treatment with insulin-like growth factor-I (IGF-I) in female patients with Laron syndrome. *Clin Endocrinol* 48: 81-87.
41. Belgorosky A, Baquedano MS, Guercio G, Rivarola MA (2008) Adrenarche: postnatal adrenal zonation and hormonal and metabolic regulation. *Horm Res* 70: 257-267.
42. Guercio G, Rivarola MA, Chaler E, Maceiras M, Belgorosky A (2003) Relationship between the growth hormone/insulin-like growth factor-I axis, insulin sensitivity, and adrenal androgens in normal prepubertal and pubertal girls. *J Clin Endocrinol Metab* 88: 1389-1393.
43. Ibáñez L, Ong K, Valls C, Marcos MV, Dunger DB, et al. (2006) Metformin treatment to prevent early puberty in girls with precocious pubarche. *J Clin Endocrinol Metab* 91: 2888-2891.
44. Ibáñez L, Valls C, Marcos MV, Ong K, Dunger DB, et al. (2004) Insulin sensitization for girls with precocious pubarche and with risk for polycystic ovary syndrome: effects of prepubertal initiation and postpubertal discontinuation of metformin treatment. *J Clin Endocrinol Metab* 89: 4331-4337.
45. Capitanio B, Sinagra JL, Ottaviani M, Bordignon V, Amantea A, et al. (2009) Acne and smoking. *Dermatoendocrinol* 1: 129-135.
46. Capitanio B, Sinagra JL, Bordignon V, Fei PC, Picardo M, et al. (2010) Underestimated clinical features of postadolescent acne. *J Am Acad Dermatol*.
47. Facchini FS, Hollenbeck CB, Jeppesen J, Chen YD, Reaven GM (1992) Insulin resistance and cigarette smoking. *Lancet* 339: 1128-1130.
48. Hautanen A, Adlercreutz H (1993) Hyperinsulinaemia, dyslipidaemia and exaggerated adrenal androgen response to adrenocorticotropin in male smokers. *Diabetologia* 36: 1275-1281.
49. Cupisti S, Häberle L, Dittrich R, Oppelt PG, Reissmann C, et al. (2010) Smoking is associated with increased free testosterone and fasting insulin levels in women with polycystic ovary syndrome, resulting in aggravated insulin resistance. *Fertil Steril* 94: 673-677.
50. Kurzen H, Berger H, Jäger C, Hartschuh W, Näher H, et al. (2004) Phenotypical and molecular profiling of the extraneuronal cholinergic system of the skin. *J Invest Dermatol* 123: 937-949.
51. Hana A, Bookin D, Henrich C, Gratchev A, Maas-Szabowski N, et al. (2007) Functional significance of non-neuronal acetylcholine in skin epithelia. *Life Sci* 80: 2214-2220.
52. West KA, Brognard J, Clark AS, Linnoila IR, Yang X, et al. (2003) Rapid Akt activation by nicotine and a tobacco carcinogen modulates the phenotype of normal human airway epithelial cells. *J Clin Invest* 111: 81-90.
53. Kihara T, Shimohama S, Sawada H, Honda K, Nakamizo T, et al. (2001) Alpha 7 nicotinic receptor transduces signals to phosphatidylinositol 3-kinase to block A beta-amyloid-induced neurotoxicity. *J Biol Chem* 276: 13541-13546.
54. Wu HT, Ko SY, Fong JH, Chang KW, Liu TY, et al. (2009) Expression of phosphorylated Akt in oral carcinogenesis and its induction by nicotine and alkaline stimulation. *J Oral Pathol Med* 38: 206-213.
55. Böhm M (2009) Neuroendocrine regulators. Novel trends in sebaceous gland research with future perspectives for the treatment of acne and related disorders. *Dermatoendocrinol* 1: 136-140.
56. Ganceviciene R, Böhm M, Fimmel S, Zouboulis CC (2009) The role of neuropeptides in the multifactorial pathogenesis of acne vulgaris. *Dermatoendocrinol* 1: 170-176.
57. Schwindinger WF, Robishaw JD (2001) Heterotrimeric G-protein $\beta\gamma$ -dimers in growth and differentiation. *Oncogene* 20: 1653-1660.
58. Zouboulis CC (2004) Acne and sebaceous gland function. *Clin Dermatol* 22: 360-366.
59. Zouboulis CC, Baron JM, Böhm M, Kippenberger S, Kurzen H, et al. (2008) Frontiers in sebaceous gland biology and pathology. *Exp Dermatol* 17: 542-551.
60. Ganceviciene R, Graziene V, Fimmel S, Zouboulis CC (2008) Involvement of the corticotropin-releasing hormone system in the pathogenesis of acne vulgaris. *Br J Dermatol* 160: 345-352.
61. Scholzen T, Armstrong CA, Bunnett NW, Luger TA, Olerud JE, et al. (1998) Neuropeptides in the skin: interactions between the neuroendocrine and the skin immune systems. *Exp Dermatol* 7: 81-96.
62. Ziegler CG, Krug AW, Zouboulis CC, Bornstein SR (2007) Corticotropin releasing hormone and its function in the skin. *Horm Metab Res* 39: 106-109.



63. Chen R, Lewis KA, Perrin MH, Vale WW (1993) Expression cloning of a human corticotropin-releasing-factor receptor. *Proc Natl Acad Sci* 90: 8967-8971.
64. Kono M, Nagata H, Umemura S, Kawana S, Osamura RY (2001) In situ expression of corticotropin-releasing hormone (CRH) and proopiomelanocortin (POMC) genes in human skin. *FASEB J* 15: 2297-2299.
65. Zouboulis CC, Seltmann H, Hiroi N, Chen W, Young M, et al. (2002) Corticotropin-releasing hormone: an autocrine hormone that promotes lipogenesis in human sebocytes. *Proc Natl Acad Sci USA* 99: 7148-7153.
66. Krause K, Schnitger A, Fimmel S, Glass E, Zouboulis CC (2007) Corticotropin releasing hormone skin signaling is receptor-mediated and is predominant in the sebaceous glands. *Horm Metab Res* 39: 166-170.
67. Böhm M, Schiller M, Ständer S, Seltmann H, Li Z, et al. (2002) Evidence for expression of melanocortin-1 receptor in human sebocytes in vitro and in situ. *J Invest Dermatol* 118: 533-539.
68. Chandras C, Koutmani Y, Kokkotou E, Pothoulakis C, Karalis KP (2009) Activation of phosphatidylinositol 3-kinase/protein kinase B by corticotropin-releasing factor in human monocytes. *Endocrinology* 150: 4606-4614.
69. Huang Q, Tatro JB (2002) Alpha-melanocyte stimulating hormone suppresses intracerebral tumor necrosis factor-alpha and interleukin-1beta gene expression following transient cerebral ischemia in mice. *Neurosci Lett* 334: 186-190.
70. Zhang L, Anthonavage M, Huang Q, Li WH, Eisinger M (2003) Proopiomelanocortin peptides and sebogenesis. *Ann N Y Acad Sci* 994: 154-161.
71. Thiboutot D, Sivarajah A, Gilliland K, Cong Z, Clawson G (2000) The melanocortin 5 receptor is expressed in human sebaceous glands and rat preputial cells. *J Invest Dermatol* 115: 614-619.
72. Zhang L, Li WH, Anthonavage M, Eisinger M (2006) Melanocortin-5 receptor: a marker of human sebocyte differentiation. *Peptides* 27: 413-420.
73. Ganceviciene R, Graziene V, Böhm M, Zouboulis CC (2007) Increased in situ expression of melanocortin-1 receptor in sebaceous glands of lesional skin of patients with acne vulgaris. *Exp Dermatol* 16: 547-552.
74. Pignatelli D, Maia M, Castro AR, da Conceição Magalhães M, Vivier J, et al. (2000) Chronic stress effects on the rat adrenal cortex. *Endocr Res* 26: 537-544.
75. Getting SJ (2006) Targeting melanocortin receptors as potential novel therapeutics. *Pharmacol Ther* 111: 1-15.
76. Chen W, Kelly MA, Opitz-Araya X, Thomas RE, Low MJ, et al. (1997) Exocrine gland dysfunction in MC5-R-deficient mice: evidence for coordinated regulation of exocrine gland function by melanocortin peptides. *Cell* 91: 789-798.
77. Rodrigues AR, Pignatelli D, Almeida H, Gouveia AM (2009) Melanocortin 5 receptor activates ERK1/2 through a PI3K-regulated signaling mechanism. *Mol Cell Endocrinol* 303: 74-81.
78. Antczak C, De Meester I, Bauvois B (2001) Ectopeptidases in pathophysiology. *Bio essays* 23: 251-260.
79. Thielitz A, Reinhold D, Vetter R, Bank U, Helmuth M, et al. (2007) Inhibitors of dipeptidyl peptidase IV and aminopeptidase N target major pathogenetic steps in acne initiation. *J Invest Dermatol* 127: 1042-1051.
80. Jeremy AH, Holland DB, Roberts SG, Thomson KF, Cunliffe WJ (2003) Inflammatory events are involved in acne lesion initiation. *J Invest Dermatol* 121: 20-27.
81. Becker T, Loch G, Beyer M, Zinke I, Aschenbrenner AC, et al. (2010) FOXO-dependent regulation of innate immune homeostasis. *Nature* 463: 369-373.
82. Reinhold D, Gohl A, Wrenger S, Reinhold A, Kühlmann UC, et al. (2009) Role of dipeptidyl peptidase IV (DP IV)-like enzymes in T lymphocyte activation: investigations in DP IV/CD26-knockout mice. *Clin Chem Lab Med* 47: 268-274.
83. Ansoorge S, Bank U, Heimbürg A, Helmuth M, Koch G, et al. (2009) Recent insights into the role of dipeptidyl aminopeptidase IV (DPIV) and aminopeptidase N (APN) families in immune functions. *Clin Chem Lab Med* 47: 253-261.
84. Thielitz A, Ansoorge S, Bank U, Tager M, Wrenger S, et al. (2008) The ectopeptidases dipeptidyl peptidase IV (DP IV) and aminopeptidase N (APN) and their related enzymes as possible targets in the treatment of skin diseases. *Front Biosci* 13: 2364-2375.
85. Ouyang W, Beckett O, Flavell RA, Li MO (2009) An essential role of the Forkhead-box transcription factor Foxo1 in control of T cell homeostasis and tolerance. *Immunity* 30: 358-371.
86. Peng SL (2008) Foxo in the immune system. *Oncogene* 27: 2337-2344.
87. Peng SL (2010) Forkhead transcription factors in chronic inflammation. *Int J Biochem Cell Biol* 42: 482-485.
88. Ikushima H, Munata Y, Ishii T, Iwata S, Terashima M, et al. (2000) Internalization of CD26 by mannose 6-phosphate/insulin-like growth factor II receptor contributes to T cell activation. *Proc Natl Acad Sci USA* 97: 8439-8444.
89. De Meester I, Korom S, Van Damme J, Scharpe S (1999) CD26, let it cut or cut it down. *Immunol Today* 20: 367-375.
90. Lendeckel U, Arndt M, Frank K, Wex T, Ansoorge S (1999) Role of alanyl aminopeptidase in growth and function of human T cells (review). *Int J Mol Med* 4: 17-27.
91. Kähne T, Reinhold D, Neubert K, Born I, Faust J, et al. (2000) Signal transduction events induced or affected by inhibition of the catalytic activity of dipeptidyl peptidase IV (DP IV, CD26). *Adv Exp Med Biol* 477: 131-137.
92. Ansoorge S, Bank U, Heimbürg A, Helmuth M, Koch G, et al. (2009) Recent insights into the role of dipeptidyl aminopeptidase IV (DPIV) and aminopeptidase N (APN) families in immune functions. *Clin Chem Lab Med* 47: 253-261.
93. Solomon LM, Fretzin DF, Pruzansky S (1970) Pilosebaceous abnormalities in Apert's syndrome. *Arch Dermatol* 102: 381-385.
94. Wilkie AO, Slaney SF, Olbridge M, Poole MD, Ashworth GJ, et al. (1995) Apert syndrome results from localized mutations of FGFR2 and is allelic with Crouzon syndrome. *Nat Genet* 9: 165-172.
95. Anderson J, Burns HD, Enriquez-Harris P, Wilkie AO, Heath JK (1998) Apert syndrome mutations in fibroblast growth factor receptor 2 exhibit increased affinity for FGF ligand. *Hum Mol Genet* 7: 1475-1483.
96. Ibrahim OA, Eliseekova AV, Plotnikov AN, Yu K, Ornitz DM, et al. (2001) Structural basis for fibroblast growth factor receptor 2 activation in Apert syndrome. *Proc Natl Acad Sci USA* 98: 7182-7187.
97. Munro CS, Wilkie AO (1998) Epidermal mosaicism producing localized acne: somatic mutation in FGFR2. *Lancet* 352: 704-705.
98. Melnik B, Vakilzadeh F, Aslanidis C, Schmitz G (2008) Unilateral segmental acneiform naevus – a model disorder towards understanding fibroblast growth factor receptor 2 function in acne? *Br J Dermatol* 158: 1397-1399.
99. Melnik B, Schmitz G (2008) FGFR2 signaling and the pathogenesis of acne. *J Dtsch Dermatol Ges* 6: 721-728.
100. Melnik BC (2009) Role of FGFR2-signaling in the pathogenesis of acne. *Dermatoendocrinol* 1: 141-156.
101. Melnik BC, Schmitz G, Zouboulis CC (2009) Anti-acne agents attenuate FGFR2 signal transduction in acne. *J Invest Dermatol* 129: 1868-1877.
102. Tsang M, Dawid IB (2004) Promotion and attenuation of FGF signaling through the Ras-MAPK pathway. *Sci STKE* 2004: pe17.
103. Ahmed Z, Schuller AC, Suhling K, Tregidgo C, Ladbury JE (2008) Extracellular point mutations in FGFR2 elicit unexpected changes in intracellular signalling. *Biochem J* 413: 37-49.
104. Robinson D, Wilms NA (1989) Successful treatment of the acne of Apert syndrome with isotretinoin. *J Am Acad Dermatol* 21: 315-316.
105. Parker TL, Roth JG, Esterly NB (1992) Isotretinoin for acne in Apert syndrome. *Pediatr Dermatol* 9: 298-300.
106. Downs AM, Codon CA, Tan R (1999) Isotretinoin therapy for antibiotic-refractory acne in Apert's syndrome. *Clin Exp Dermatol* 24: 461-463.
107. Ju Q, Zouboulis CC, Xia L (2009) Environmental pollution and acne: chloracne. *Dermatoendocrinol* 1: 125-128.
108. Geusau A, Khorchide M, Mildner M, Pammer J, Eckhart L, et al. (2005) 2,3,7,8-Tetrachlorodibenzo-p-dioxin impairs differentiation of normal human epidermal keratinocytes in a skin equivalent model. *J Invest Dermatol* 124: 275-277.
109. Neuberger M, Landvoigt W, Derntl F (1991) Blood levels of 2,3,7,8-tetrachlorodibenzo-p-dioxin in chemical workers after chloracne and in comparison groups. *Int Arch Occup Environ Health* 63: 325-327.
110. Scerri L, Zaki I, Millard LG (1995) Severe halogen acne due to a trifluoromethylpyrazole derivative and its resistance to isotretinoin. *Br J Dermatol* 132: 144-148.



111. Prough RA (1996) Introduction: basal and inducible expression of cytochromes P450 and related enzymes. *FASEB J* 10: 807-808.
112. Monk SA, Denison MS, Rice RH (2003) Reversible stepwise negative regulation of CYP1A1 in cultured rat epidermal cells. *Arch Biochem Biophys* 419: 158-169.
113. Wanner R, Panteleyev A, Henz BM, Rosenbach T (1996) Retinoic acid affects the expression rate of the differentiation-related genes aryl hydrocarbon receptor, ARNT and keratin 4 in proliferative keratinocytes only. *Biochim Biophys Acta* 1317: 105-111.
114. Mimura J, Fujii-Kuriyama Y (2003) Functional role of AhR in the expression of toxic effects by TCDD. *Biochim Biophys Acta* 1619: 263-268.
115. Panteleyev AA, Bickers DR (2006) Dioxin-induced chloracne-reconstructing the cellular and molecular mechanisms of a classic environmental disease. *Exp Dermatol* 15: 705-730.
116. Tang NJ, Liu J, Coenraads PJ, Dong L, Zhao LJ, et al. (2008) Expression of AhR, CYP1A1, GSTA1, c-fos and TGF- α in skin lesions from dioxin-exposed humans with chloracne. *Toxicol Lett* 177: 182-187.
117. Tannheimer SL, Ethier SP, Caldwell KK, Burchiel SW (1998) Benzo[a]pyrene- and TCDD- induced alterations in tyrosine phosphorylation and insulin-like growth factor signaling pathways in the MCF-10A human mammary epithelial cell line. *Carcinogenesis* 19:1291-1297
118. Tsai KS, Yang RS, Liu SH (2004) Benzo[a]pyrene regulates osteoblast proliferation through an estrogen receptor-related cyclooxygenase-2 pathway. *Chem Res Toxicol* 17: 679-684.
119. Davis JW 2nd, Melendez K, Salas VM, Lauer FT, Burchiel SW (2000) 2,3,7,8-Tetrachlorodibenzo-p-dioxin (TCDD) inhibits growth factor withdrawal-induced apoptosis in the human mammary epithelial cell line, MCF-10A. *Carcinogenesis* 21: 881-886.
120. Afaq F, Zaid MA, Pelle E, Khan N, Syed DN et al. (2009) Aryl hydrocarbon receptor is an ozone sensor in human skin. *J Invest Dermatol* 129: 2396-2403.
121. Bettoli V, Trimurti S, Lombardi AR, Virgili A (1998) Acne due to amineptine abuse. *J Eur Acad Dermatol Venereol* 10: 281-283.
122. De Gálvez Aranda MV, Sánchez PS, Alonso Corral MJ, Bosch García RJ, Gallardo MA, et al. (2001) Acneiform eruption caused by amineptine. A case report and review of the literature. *J Eur Acad Dermatol Venereol* 15: 337-339.
123. Yeung CK, Chan HH (2004) Cutaneous adverse effects of lithium: epidemiology and management. *Am J Clin Dermatol* 5: 3-8.
124. Oztas P, Aksakal AB, Oztas MO, Onder M (2001) Severe acne with lithium. *Ann Pharmacother* 35: 961-962.
125. Mao Z, Liu L, Zhang R, Li X (2007) Lithium reduces FoxO3a transcriptional activity by decreasing its intracellular content. *Biol Psychiatry* 62: 1423-1430.
126. Essaghir A, Dif N, Marbehant CY, Coffey PJ, Demoulin JB (2009) The transcription of FOXO genes is stimulated by FOXO3 and repressed by growth factors. *J Biol Chem* 284: 10334-10342.
127. Polter A, Yang S, Zmijewska AA, van Groen T, Paik JH, et al. (2009) Forkhead box, class O transcription factors in brain: regulation and behavioral manifestation. *Biol Psychiatry* 65: 150-159.
128. Maiese K, Chong ZZ, Shang YC (2007) "Sly as a FOXO": new paths with Forkhead signaling in the brain. *Curr Neurovasc Res* 4: 295-302.
129. Nordlind K, Azmitia EC, Slominski A (2008) The skin as a mirror of the soul: exploring the possible roles of serotonin. *Exp Dermatol* 17: 301-311.
130. Liang B, Moussaif M, Kuan CJ, Gargus JJ, Sze JY (2006) Serotonin targets the DAF-16/FOXO signaling pathway to modulate stress responses. *Cell Metab* 4: 429-440.
131. Cowen DS, Johnson-Farley NN, Travkina T (2005) 5-HT receptors couple to activation of Akt, but not extracellular-regulated kinase (ERK), in cultured hippocampal neurons. *J Neurochem* 93: 910-917.
132. Johnson-Farley NN, Kertesz SB, Dubyak GR, Cowen DS (2005) Enhanced activation of Akt and extracellular-regulated kinase pathways by simultaneous occupancy of Gq-coupled 5-HT2A receptors and Gs-coupled 5-HT7A receptors in PC12 cells. *J Neurochem* 92: 72-82.
133. Cowen DS (2007) Serotonin and neuronal growth factors - a convergence of signaling pathways. *J Neurochem* 101: 1161-1171.
134. Kontaxakis VP, Skourides D, Ferentinos P, Havaki-Kontaxaki BJ, Papadimitriou GN (2009) Isotretinoin and psychopathology: a review. *Ann Gen Psychiatry* 8: 2.
135. Melnik BC (2010) Is nuclear deficiency of FoxO1 due to increased growth factor/PI3K/Akt-signalling in acne vulgaris reversed by isotretinoin treatment? *Br J Dermatol*.