

Fuzzy Logic Control of a SEPIC Converter for a Photovoltaic System

Meryem Oudda* and Abdeldjebar Hazzab

Department of Electric and Electronics Engineering, Tahri Mohamed Bechar University, Algeria

Abstract

In this work, a fuzzy logic controller is used to control the output voltage of a photovoltaic system with a DC-DC converter; type Single Ended Primary Inductor Converter (SEPIC). The system is designed for 210 W solar PV (SCHOTT 210) panel and to feed an average demand of 78 W (24V). This system includes solar panels, SEPIC converter and fuzzy logic controller. The SEPIC converter provides a constant DC bus voltage and its duty cycle controlled by the fuzzy logic controller which is needed to improve PV panel's utilization efficiency. A fuzzy logic controller (FLC) is also used to generate the PWM signal for the SEPIC converter.

Keywords: Photovoltaic system; DC-DC converter; Duty cycle

Abbreviations: PV: Photovoltaic; SEPIC: Single Ended Primary Inductor Converter; FLC: Fuzzy Logic Controller

Introduction

The non-renewable source of energy is depleting rapidly and the demand for power is increasing day by day. To overcome this problem, generation of electric power from renewable source of energy should be made effective and efficient [1].

The energy source which the society can depend on is renewable energy since it is clean, pollution free, and endless. Photovoltaic (PV) system is one of power generations that utilize renewable energy [2]. To reduce consumption of conventional energy, then the PV system must be connected to grid, either directly or through back-up battery bank. However, the PV system has low efficiency because of the power generated from PV systems depends on the irradiation and temperature variation [2].

For the control of the PV systems, there are various types of DC-DC converters such as, Buck converter, Boost converter and Buck-Boost converter. The output of buck converter is less than the input voltage whereas the boost converter output is greater than the input voltage. The polarity of buck-boost converter is inversed of input signal. Yusivar et al. have been proposed Buck-Converter Photovoltaic Simulator [3]. Whereas Single Ended Primary Inductor Converter (SEPIC) is a special type of DC-DC converter which maintains a constant output voltage even under varying input conditions and load conditions [4].

From the literature survey it can be understood that SEPIC is widely used converter topology in renewable source based energy generation. Venkatanarayanan et al. are presented photovoltaic energy system with SEPIC converter [5]. The SEPIC converter is proposed also by El Khateb et al. [6]. Another recent search [7] a SEPIC converter for a standalone PV system is chosen. SEPIC converter also overcomes the drawback of buck-boost converter. The performance of SEPIC converter can further be improved by using a suitable control scheme [2].

The control of this SEPIC converter is a much discussed and invested very subject. Indeed, this converter is nonlinear in nature and different approaches have been used to control it. Conventional control modes such as voltage mode control and current mode control require a good knowledge of the converter and therefore a fairly accurate model [1]. Proportional-integral control for SEPIC converter is presented by Venkatanarayanan et al. [8], Current mode control and PI controller have been proposed by Reddy et al. [9].

These controllers are easy to implement and simple to design, but their performance generally depends on the operating point so that too large disturbance, wide load variation ranges or supply voltage variations can make the choice of the parameters very difficult for different operating conditions.

However, a very different approach is offered by the fuzzy logic control (FLC), which does not require precise mathematical model or complex calculation [10]. The fuzzy control technique is based primarily on human understanding of the process control and on qualitative rules. The objective of this research is to develop a fuzzy voltage regulator for a SEPIC converter.

This paper is organized as follows. In section 2, the photovoltaic array model is presented. Section 3 presents the SEPIC converter, while the design of the fuzzy logic controller for the SEPIC converter has been done in section 4. Simulation results are shown in section 5. Finally conclusion is given in section 6.

Photovoltaic Array Model

Photovoltaic is the field of technology and research related to the devices which directly convert sunlight into electricity using semiconductors that exhibit the photovoltaic effect.

The photovoltaic panel is composed of many cells, placed in series N_s or in shunt N_{sh} . Where it can be modelled by current source connected in parallel with diode according with shunt and series resistor noted by R_{sh} and R_s as illustrated in Figure 1 [11].

The output current is given by the following equations:

$$I = I_{ph} - I_D \quad (1)$$

*Corresponding author: Meryem Oudda, Department of Electric and Electronics Engineering, Tahri Mohamed Bechar University, Bechar, 08000, Algeria, Tel: 049-81-90-24; Fax: 213664101910; E-mail: ouddameryem@gmail.com

Received March 06, 2016; Accepted June 20, 2016; Published June 22, 2016

Citation: Oudda M, Hazzab A (2016) Fuzzy Logic Control of a SEPIC Converter for a Photovoltaic System. J Fundam Renewable Energy Appl 6: 212. doi:10.4172/20904541.1000212

Copyright: © 2016 Oudda M, et al. This is an open-access article distributed under the terms of the Creative Commons Attribution License, which permits unrestricted use, distribution, and reproduction in any medium, provided the original author and source are credited.

$$I = I_{ph} - I_0 \left[\exp\left(\frac{q(V+R_s I)}{AK_B T}\right) - 1 \right] - \frac{V+R_s I}{R_{sh}} \quad (2)$$

I_{ph} : Photo-current; A: Ideality factor; K_B : Boltzmann's constant; T: Cell temperature; I_D : Diode current; R_{sh} : Series resistance; I_0 : Saturation current; q: Electronic charge; R_{sh} : Shunt resistance; V: Cell voltage; I: Cell current

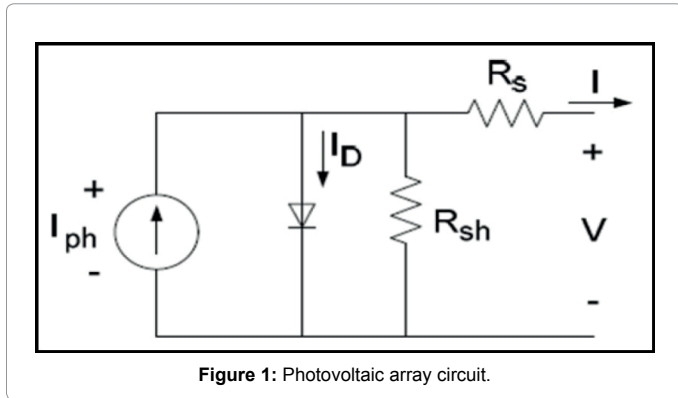

Typically, the shunt resistance (R_{sh}) is very large and the series resistance (R_s) is very small [12]. Therefore, it is common to neglect these resistances in order to simplify the solar cell model. The resultant ideal voltage-current characteristic of a photovoltaic cell is given by equation 3.

$$I = I_{ph} - I_0 \left[e^{\frac{qV}{kT}} - 1 \right] \quad (3)$$

Figures 2 and 3 show the behavior of a photovoltaic module simulation used in this study, in accordance to solar radiation variation and at a constant temperature.

The typical output power characteristics of a PV array under various degrees of irradiation is illustrated by Figure 2. It can be observed in Figure 3 that there is a particular optimal voltage for each irradiation level that corresponds to maximum output power. Therefore by adjusting the output current (or voltage) of the PV array, maximum power from the array can be drawn.

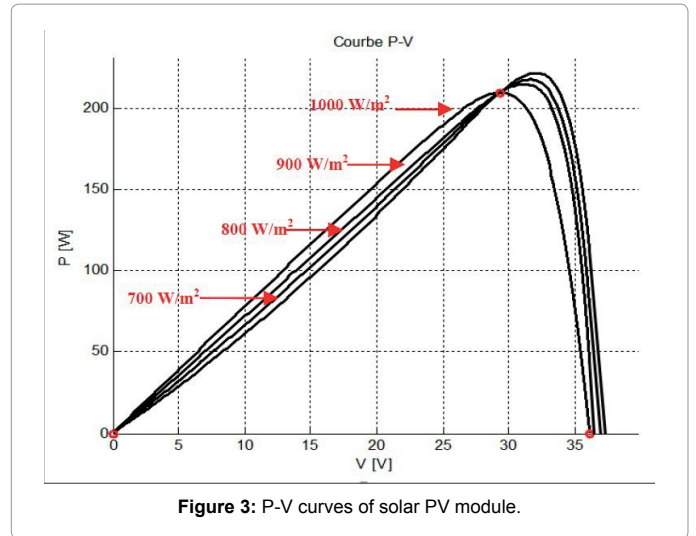
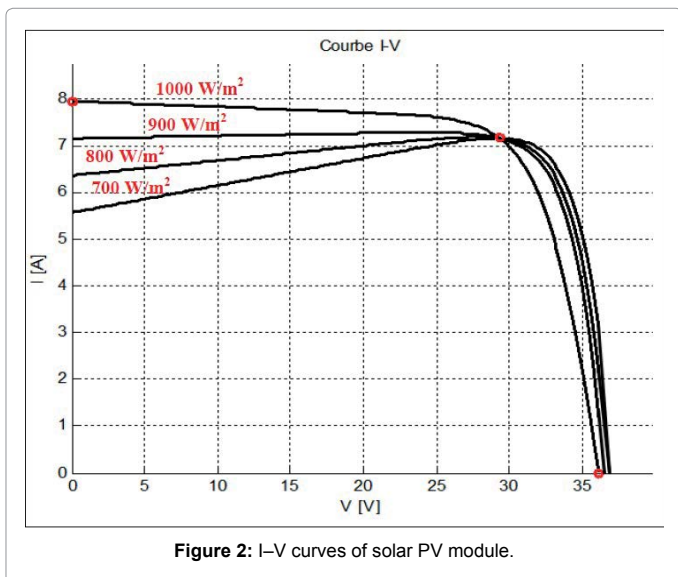

As we can see in the curve of the Figure 2, the current increase is highly affected by the solar radiation.

DC-DC/SEPIC Converter

A DC-DC converter with simpler structure and higher efficiency has been an active research topic in the power electronics [13]. The proposed converter is based on DC to DC converter to maintain the constant output voltage [1].

Single Ended Primary Inductor Converter (SEPIC) converter consists of a switch S with duty cycle α , a diode, two inductors L_1 and L_2 , two capacitors C_1 and C_2 and a load Resistor. The circuit diagram of a SEPIC converter is shown in Figure 4.

A SEPIC is a type of DC-DC converter allowing the electrical potential (voltage) at its output to be less than, greater than, or equal to that at its input; the output of the SEPIC is controlled by the duty cycle of the control transistor. SEPIC is effectively a boost converter followed by a buck-boost converter, consequently it is like to a conventional buck-boost converter, other than has advantages of having non-inverted output (the output has the same voltage polarity as the input), passing through a series capacitor to couple energy from the input to the output (and thus can respond more gracefully to a short-circuit output), and being able of factual shutdown: after the switch "S" is turned off, its output drops to 0V, following a rather hefty transient abandon of charge [14].

Figure 4 shows a simple circuit diagram of a SEPIC converter can both step up and step down the input voltage, while maintaining the same polarity and the same ground reference for the input and output.

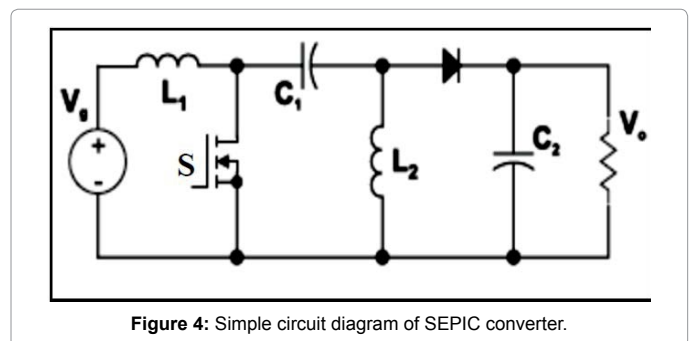
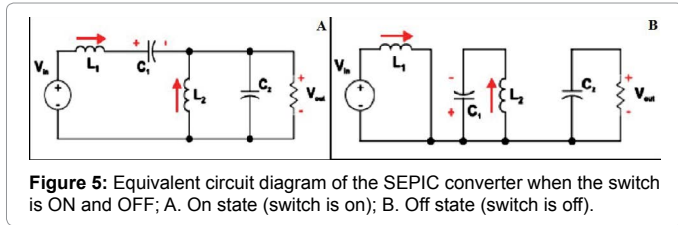

Figure 5 shows the circuit when the power switch is turned on and off (respectively in Figure 5A and Figure 5B). When the switch is turned on; the first inductor; L_1 is charged from the input voltage source during this time. The second inductor L_2 takes energy from the first capacitor C_1 , and the output capacitor C_2 is left to provide the load current.



When the switch is turned on, the input inductor is charged from the source, and the second inductor is charged from the first capacitor. No energy is supplied to the load capacitor during this time. Inductor current and capacitor voltage polarities are marked in Figure 4.

When the power switch is turned off, the energy stored in inductor L_1 is transferred to C_1 . The energy stored in L_2 is transferred to C_2 through the diode and supplying the energy to load [9], as shown in Figure 5B. The second inductor L_2 is also connected to the load during this time.

The output capacitor sees a pulse of current during the off time, making it inherently noisier than a buck converter.

The amount that the SEPIC converters increase or decrease the voltage depends primarily on the Duty Cycle and the parasitic elements in the circuit.

The output of an ideal SEPIC converter is:

$$V_{OUT} = \frac{D}{1-D} V_{in} \tag{4}$$

A SEPIC converter is to process the electricity from the PV system. This converter either increases or decreases the PV system voltage at the load. The proposed SEPIC converter operates in buck mode.

The Fuzzy Logic Controller for the SEPIC Converter

In fuzzy logic controller (FLC) design, one should identify the main control variables and determine the sets that describe the values of each linguistic variable. The input variables of the FLC are the output voltage error (eV_{out}) and the change of this error (ΔeV_{out}) of the SEPIC converter. The output of the FLC is the duty cycle of (α) of the PWM signal, which regulates the output voltage. The triangular membership functions are used for the FLC for easier computation. A five-term fuzzy set, i.e., negative big (NB), negative small (NS), zero (Z), Positive small (PS), and positive big (PB), is defined to describe each linguistic variable. The fuzzy rules of the proposed SEPIC DC-DC converter can be represented in a symmetric form (Table 1). For the output variable (α), five-term fuzzy is defined to give sharpness to the regulation: negative big (NB), negative small (NS), zero (Z), Positive small (PS) and positive big (PB).

The variables of the FLC for the SEPIC converter are as follow:

- The first input is the error in the output voltage (eV_{out}):

$$eV_{OUT}(k) = V_{Ref} - V_{out}(k) \tag{5}$$

- The second input is the variation (the change) in error (ΔeV_{out}):

$$\Delta eV_{OUT}(k) = eV_{out}(k) - eV_{out}(k-1) \tag{6}$$

- The single output variable (α) is duty cycle.

Where:

- V_{Ref} : is the reference output voltage.

- $V_{out}(k)$ is the measured output voltage in the K^{th} sample.

The Block diagram of the control SEPIC converter with the Fuzzy Logic controller is presented in Figure 6, where $\alpha(k)$ is sent to the PWM generator. PWM generator generates the necessary switching signal for the switch in the converter.

$K_{eV_{out}}$ is the control gain of input eV_{out} .

$K_{\Delta eV_{out}}$ is the control gain of input $\Delta eV_{out}(k)$.

K_{α} is the control gain of output α .

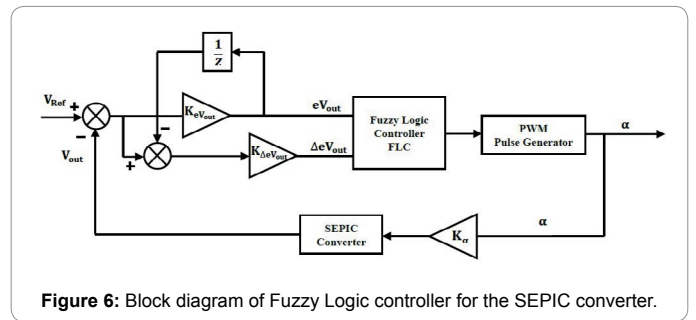

Figure 6: Block diagram of Fuzzy Logic controller for the SEPIC converter.

The membership functions $\mu_{eV_{out}}$ and $\mu_{\Delta eV_{out}}$ for eV_{out} and ΔeV_{out} respectively are represented in Figure 7A. The membership function for the output variable α is represented in Figure 7B. All the functions are defined on a normalized interval $[-1, 1]$.

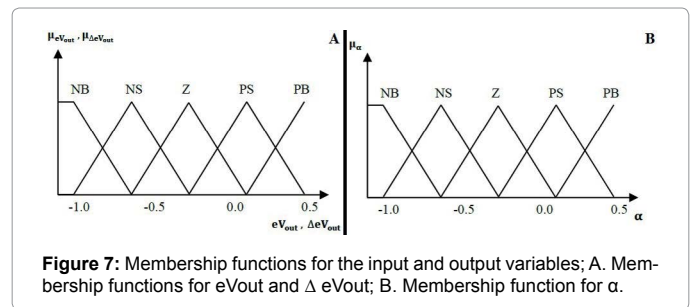

Figure 7: Membership functions for the input and output variables; A. Membership functions for eV_{out} and ΔeV_{out} ; B. Membership function for α .

The rules of the fuzzy logic controller are shown in Table 1.

$eV_{out} \backslash \Delta eV_{out}$	NB	NS	Z	PS	PB
NB	NB	NB	NB	NS	Z
NS	NB	NB	NS	Z	PB
Z	NB	NS	Z	PS	PB
PS	NS	Z	PS	PB	PB
PB	Z	PS	PB	PB	PB

Table 1: Fuzzy control rules.

Fuzzy control rules are derived from the analysis of the converter behavior:

When the output of the converter is far from the set point (Positive Big or Negative Big), the duty cycle should be close to zero or one so as to bring to the set point quickly.

When the output of the converter is approaching to the set point (Negative Small or Positive Small), a small change of the duty cycle is necessary.

When the output of the converter is approaching very close to the set point, duty cycle must be kept constant in order to prevent the overshoot.

Simulation Results

The photovoltaic array that we use in this paper is SCHOTT Solar (SCHOTT POLYTM 210); the characteristics of this array are given in Table 2.

Maximum Power	$P_{max} = 210 \text{ W}$
Open circuit voltage	$V_{oc} = 36.1 \text{ V}$
Short circuit current	$I_{sc} = 7.95 \text{ A}$
Voltage at maximum power	$V_{max} = 29.3 \text{ V}$
Current at maximum power	$I_{max} = 7.16 \text{ A}$

Table 2: Electrical data apply to standard test conditions (STC): (T = 25°C, G = 1000 W/m²).

Figures 8 and 9 show the simulation result of the PV model.

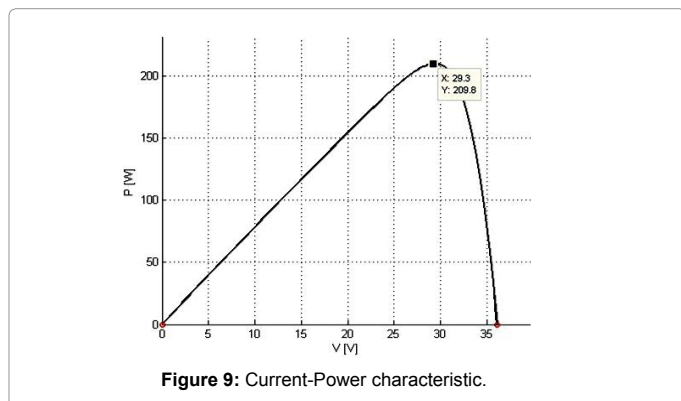
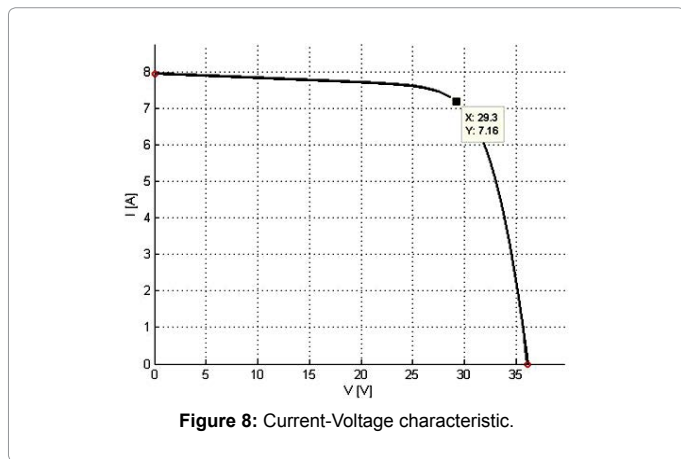

The parameters of the SEPIC converter used in this study are given in Table 3.

Switching frequency	20 KHz
Input Voltage (V_{in})	$V_{in} = 29.3 \text{ V}$
Output Voltage (V_{out})	$V_{out} = 24 \text{ V}$
Load resistance	$R_{load} = 7.38 \Omega$
Inductance L1	$L1 = 460 \mu\text{H}$
Inductance L2	$L2 = 460 \mu\text{H}$
Capacitor C1	$C1 = 8.4 \mu\text{F}$
Capacitor C2	$C2 = 0.0163 \text{ F}$

Table 3: The simulation parameters of SEPIC converter.

In the full model; the SEPIC converter is connected to the PV panel, and the duty cycle of this is controlled using the Fuzzy Logic Controller. The results are provided under standard test conditions; G = 1000 W/m² and T = 25°C.

Figure 10 shows the simulation results obtained from the model; $V_{out} = 24\text{V}$; $I_{out} = 3.25\text{A}$ and Power = 78 W.

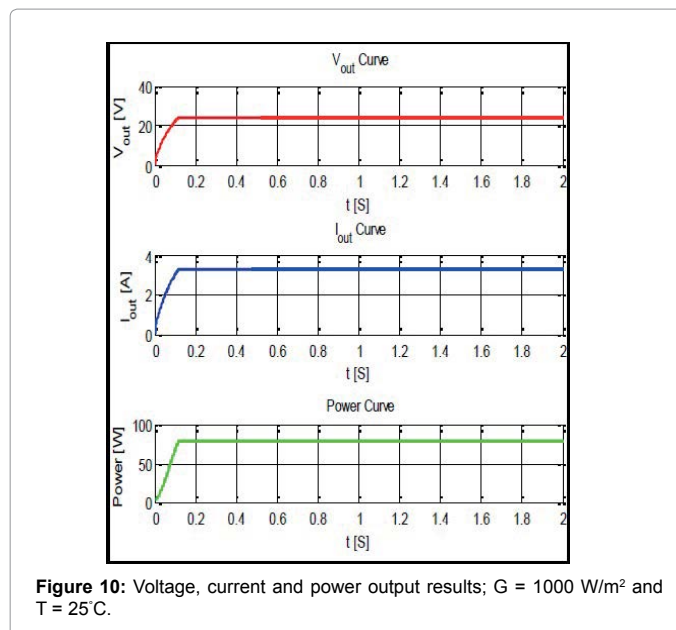

Figure 10: Voltage, current and power output results; G = 1000 W/m² and T = 25°C.

According this (Figure 10); we notice that since the time 0.1s the model gave a stable voltage (24 V), and thus a current and a power so stable.

To prove the efficiency of the integration of SEPIC converter controlled by the fuzzy logic controller for the photovoltaic system, we have studying the influence of the temperature and the solar irradiation separately.

Influence of temperature

For stable irradiation (G = 1000 W/m²), and for a variable temperature, we obtain the results shown in the figures below.

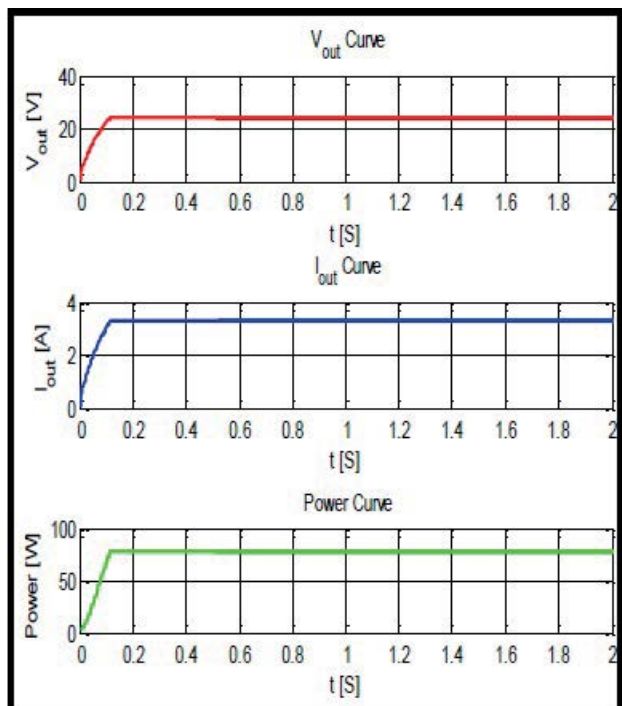

Figure 11: Voltage, current and power output results; $G = 1000 \text{ W/m}^2$ and $T = 35^\circ\text{C}$.

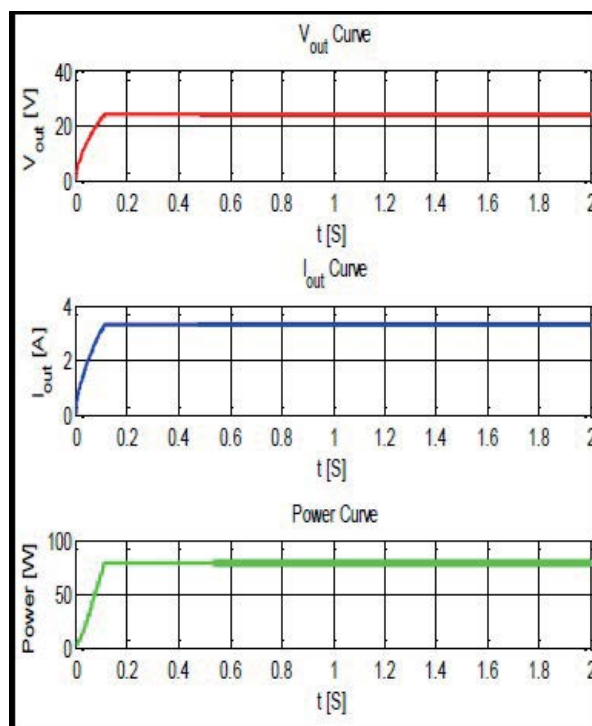

Figure 13: Voltage, current and power output results; $G = 1000 \text{ W/m}^2$ and $T = 55^\circ\text{C}$.

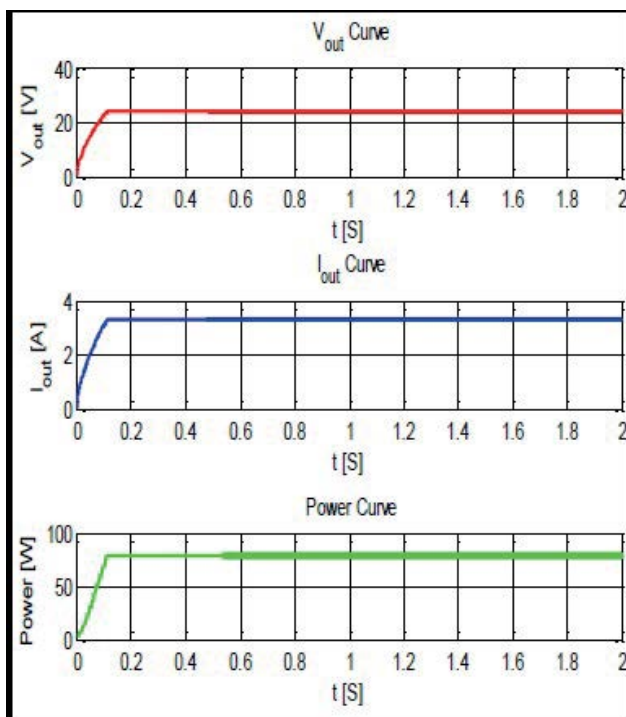

Figure 12: Voltage, current and power output results; $G = 1000 \text{ W/m}^2$ and $T = 45^\circ\text{C}$.

From this three figures above (Figures 11-13); it is clear that for a variable temperature value, we obtain the desired voltage (24 V), and it is so stable since 0.1s.

Influence of irradiation

For stable temperature ($T = 25^\circ\text{C}$), and for a variable solar irradiation, we obtain the results shown in the figures below.

Figures 14-16 shows the simulation results obtained from the model ($T = 25^\circ\text{C}$); for $G = 900\text{W/m}^2$, $G = 800\text{W/m}^2$ and $G = 700\text{W/m}^2$ respectively.

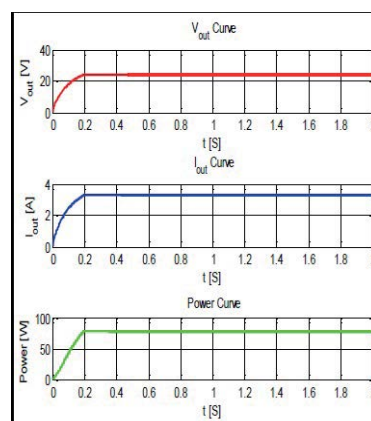

Figure 14: Voltage, current and power output results; $T = 25^\circ\text{C}$ and $G = 900 \text{ W/m}^2$.

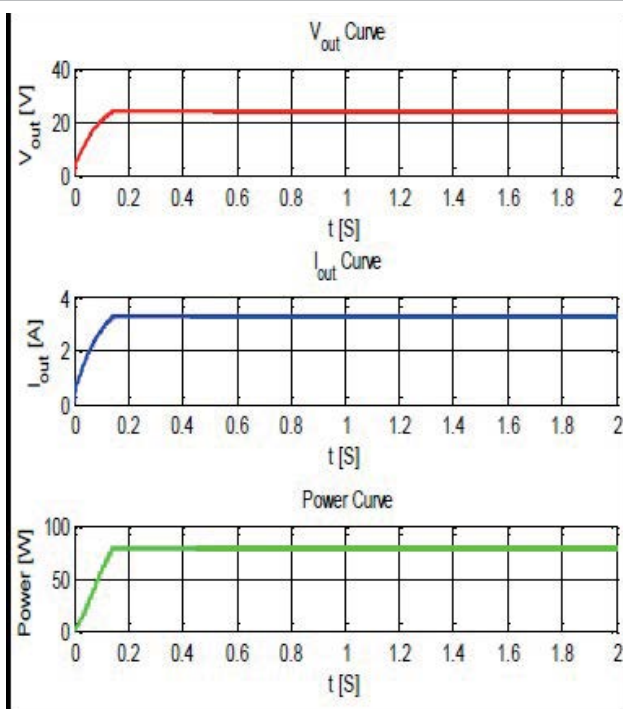

Figure 15: Voltage, current and power output results; T = 25°C and G = 800 W/m².

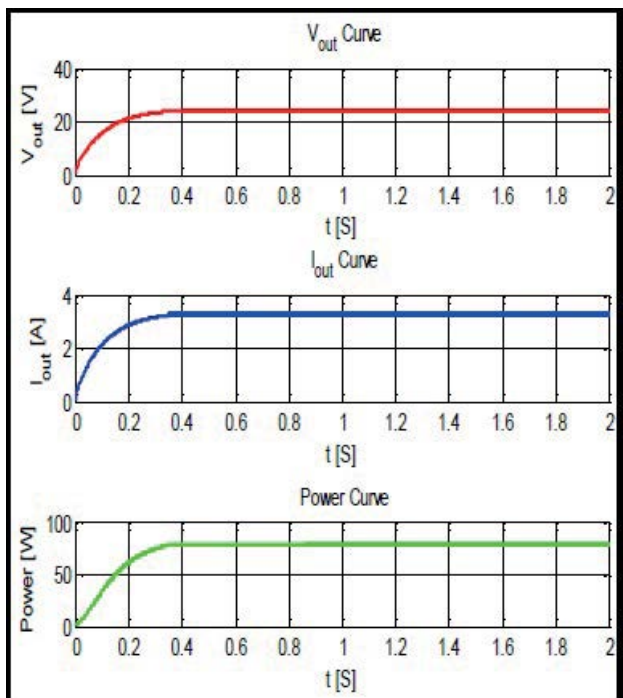

Figure 16: Voltage, current and power output results; T = 25°C and G = 700 W/m².

From the figures 14, 15 and 16; it is notable that the output voltage is 24V, even if there are a variation in the solar irradiance.

The following table (Table 4) summarizes the results given from the study.

The temperature and solar irradiation variations can be addressed by the FLC controller, and this is observed from the corresponding table, and generally the steady state is not exceeding 0.4s.

G and T variation		V _{out} (V)	I _{out} (A)	P (W)
25°C	900 W/m ²	24.03	3.256	78.23
	800 W/m ²	24.04	3.257	78.29
	700 W/m ²	24.03	3.257	78.27
1000W/m ²	35°C	24.04	3.257	78.29
	45°C	24.03	3.257	78.28
	55°C	24.03	3.257	78.28

Table 4: Temperature and solar irradiation influence results.

Conclusion

The SEPIC performs the voltage conversion from positive source voltage to positive load voltage. Due to the time variations and switching nature of the power converters, their dynamic behavior becomes highly non-linear. In this paper; a stand-alone solar-PV energy generation system with a SEPIC; DC-DC converter controlled by a Fuzzy Logic Controller has been designed and the efficiency of the system has been presented under variation in temperature and solar irradiation. This study has successfully demonstrated the design, analysis and suitability of fuzzy logic controller for SEPIC converter.

References

- Mahendran G, Kandaswamy KV (2013) Ant Colony Optimized Tuned DC-DC Converter ", Int J Comp Appl 2013: 16-21.
- Dunia J, Mwyniwiwa BM (2013) Performance Comparison between ĆUK and SEPIC Converters for Maximum Power Point Tracking Using Incremental Conductance Technique in Solar Power Applications. Int J Electrical, Computer, Energetic, Electronic and Communication Engineering 7: 1638-1643.
- Yusivar F, Farabi MY, Suryadiningrat R, Ananduta WW, Syaifudin Y (2011) Buck-Converter Photovoltaic Simulator. Int J Power Electronics Drive Sys 1: 156-167.
- Srivastav S, Singh S (2011) An Introduction To Sepic Converters. Int Referred Res J 2: 14-15.
- Venkatanarayanan S, Saravanan M (2014) Fuzzy logic based PV energy system with SEPIC converter. J Theoretical Appl Inform Technol 59: 89-95.
- El Khateb AH, Rahim NA, Selvaraj J (2012) Fuzzy logic control approach of a maximum power point employing SEPIC converter for standalone photovoltaic system.
- Thambi G, Prem Kumar S, Murali Krishna Y, Aruna M (2015) Fuzzy-Logic-Controller-Based SEPIC Converter for MPPT in Standalone PV systems. Int Res J Engineering Technol 2: 492-497.
- Venkatanarayanan S, Saravanan M (2014) Proportional-integral Control for SEPIC Converter. Res J Appl Sci Engineer and Technol 8: 623-629.
- Krishna Reddy TGL, Ramamurthyraju P, Revanth KV (2013) Analysis of SEPIC for PV-Applications using PI Controller and Current Mode Control. Int J Sci Res Dev 1: 1821-1824.
- Kung YS, Liaw CM (1994) A Fuzzy Controller improving a Linear Model Following Controller for Motor Drives. IEEE Transactions on Fuzzy Systems 2: 194-202.
- Bouzeria H, Fetha C, Bahi T, Abadlia I, Layate Z, et al. (2015) Fuzzy Logic

-
- Space Vector Direct Torque Control of PMSM for Photovoltaic Water Pumping System. Energy Procedia 74: 760-771.
12. Chen YM, Liu YC, Hung SC, Cheng CS (2007) Multi-Input Inverter for Grid-Connected Hybrid PV/Wind Power System. IEEE Transactions on Power Electronics 22: 1070-1077.
13. Ganesh S, Janani J, Angel GB (2014) A Maximum Power Point Tracker for PV Panels Using SEPIC Converter. Int J Electric Comp Energetic, Electron Commun Engineer 8: 356-361.
14. Ramkumar A, Shini Florence SV (2015) Analysis of Single Phase AC-DC SEPIC Converter using Closed Loop Techniques. Int J Adv Res Electric Electron and Instrumen Engineer 4: 756-766.