

Fuel Contamination on the Large Transport Airplanes

Behbahani-Pour MJ* and Radice G

Department of Aerospace Engineering, Glasgow University, G12 8QQ, UK

Abstract

There have been different cases of aircraft accidents, due to the water contamination in the aviation fuel. Since large transport airplanes fly at very high altitudes, where ambient temperature can reach -6°C , water may freeze causing blockages in the fuel lines, filters, booster pumps, etc., and lead to engine thrust reduction and or engine shut down. Microbiological contamination of the fuel, due to microbial growth in the fuel, it can result in fuel tank structure corrosion, and in turn, leads to fuel leak. Fuel leak on hot engine surfaces or hot brakes can result into fire or explosion. In addition, the biological microorganisms in aviation fuel, can cause other technical problems such as it leads to fuel quantity gauge malfunctions, and fuel filter clogging. Therefore, it is important to eliminate or reduce the presence of the water and microbial growth in the fuel. The aim of this paper is to increase flight safety by minimizing the effect of water and biological contamination in the jet fuel. The proposed methodology, water contamination is eliminated by extracting water from fuel by using water/fuel separator and in addition, microbial contamination eliminated by uses the ultrasonic technology to destroy the bacteria in the fuel. Several experiments performed by taking fuel samples checked for presence of microbes, and then subjected to ultrasonic waves. The fuel sample located in a stainless steel and where it subjected to the ultrasonic externally (ultrasonic transmitter) located outside the tank and not on direct contact with fuel. The result show ultrasonic can heat up the fuel, and destroy the microorganisms effectively. During the experiments it has been observed that, for every five minutes of subjecting the fuel sample of 600 milliliters to ultrasonic of 42 KHz with power intensity of 50 watts, the fuel temperature increased by an average of about 6.2°C .

Keywords: Fuel contamination; Transport

Abbreviations: A/C: Aircraft; DMC: Display Management Computer; ECAM: Electronic Centralized Aircraft Monitor; ENG: Engine; FADEC: Full Authority Digital Electronic Control; FCMC: Fuel Control Management Computer; FWC: Flight Warning Computer; FTSC: Fuel Tank Sterilization Controller; HI: High; LVL: Level; LP: Low Pressure; Press: Pressure; PRV: Pressure Relief Valve; QTY: Quantity; SNR: Sensor; SOV: Shut Off Valve; Temp: Temperature; VLV: Valve; TX: Transmitter

Introduction

The aim of this article is to present a new alternate technique; which can be used to minimize the effect of fuel contamination in the aviation fuel on large transport airplanes. Water contamination in aviation fuel continues to contribute to aircraft incidents and accidents and, at times, fatal accidents. A review of US National Transportation Safety Board briefs of aircraft accidents states that the 114 aircraft accidents was due to fuel contamination with water, occurred between January 7, 1980, and September 11, 1981. Aircraft engine will tolerate a small amount of free water, maximum of 30 PPM, if it is uniformly dispersed (FAA Advisory Circular Number: 20-125, PP1-4, 1985).

Literature Review

Current water removal/prevention on large transport airplanes includes installation of water scavenging system, and regular drainage of fuel tanks for water. To prevent large amount of free water building up in the fuel tanks, the aircraft is fitted with a water scavenge system that uses jet pumps operated by motive flow from the fuel booster pumps. The jet pumps draw fluid from the bottom of the tank, and inject it close to the inlet of each fuel booster pump [1]. The main disadvantage of current water scavenge system is that the scavenge jet pumps only operate, if the fuel booster pump is operating, hence when aircraft is stationary and parked overnight, water accumulate inside the tank due to condensation, and moist air entering the tanks through fuel vent ports.

Foreign objects can block the jet pump, analysis of the jet pumps on British Airways, Boeing B777, flight 38, after the accident in 17 January 2008, showed that one of jet pump found blocked by 6 mm plastic disc. UK aircraft accident investigation branch (AAIB) have issued safety recommendation for the Civil Aviation authority, Boeing, and Rolls-Royce to develop changes in aircraft to avoid fuel flow restriction to engine due to water in fuel to form ice (Air Accidents Investigation Branch, P103, 2010). In addition, water in fuel can freeze at -1°C , and turn to ice and block the scavenge jet pumps. In all large transport airplanes, there are several fuel/water drain valves, the maintenance personnel have to open the drain valve, and to drain water accumulation in the bottom of the tank. However, there are many problems associated with the drain valves, for example, a defective drain valve seal can result into fuel leakage, and this in turn, and it requires fuel tank entry to replace the defective drain valve. To enter fuel tank, it requires the aircraft to be defueled, purged with dry air to get rid of the fumes. Fuel tank purging can take up to 24 hours. This will result into flight cancellation. The other problems associated with fuel drain valves is that in cold weather, the water in fuel tank freezes thus prevent the drain valves from opening [2].

The standard design practice to provide water drain valves at tank low points allowing maintenance personnel to drain off any water, however it takes a long time and the standard maintenance practices for

*Corresponding author: Behbahani-Pour MJ, Department of Aerospace Engineering, Glasgow University, G12 8QQ, UK, Tel: 0096550411737; E-mail: behbaa@yahoo.co.uk

Received September 16, 2017; Accepted October 03, 2017; Published October 07, 2017

Citation: Behbahani-Pour MJ, Radice G (2017) Fuel Contamination on the Large Transport Airplanes. J Aeronaut Aerospace Eng 6: 200. doi: 10.4172/2168-9792.1000200

Copyright: © 2017 Behbahani-Pour MJ, et al. This is an open-access article distributed under the terms of the Creative Commons Attribution License, which permits unrestricted use, distribution, and reproduction in any medium, provided the original author and source are credited.

water management often ineffective [3]. Aircraft fuel tanks constructed with water drain sumps, however, it is practically impossible to drain all water from the tanks, but it is done at certain regular intervals. The greatest single danger of water in fuel is from human error that allows fuel contaminated with water to enter aircraft without checking the fuel for water presence before aircraft departure [4].

Microbial contamination of fuel, can result into corrosion of fuel tank thus result in fuel leakage, and consequently it may result into fire and or an explosion. In the proposed methodology, fuel is subjected to ultrasonic which located outside the fuel tank. Ultrasonic will disinfect fuel from microorganism, and heat up the fuel to acceptable safe level. Fuel subjected to ultrasonic for short period of time of 5 to 10 minutes depending upon fuel quantity. In large transport aircrafts, fuel is heated through heat exchangers by using very hot engine oil and hot engine bleed air, then temperature of fuel is controlled by modulating the hot bleed air or engine oil to the heat exchangers. In proposed design, the fuel temperature in the fuel tank is measured continuously, and if the fuel temperature rises to certain unsafe limit, then ultrasonic propagation inhibited.

Fuel tank inerting technologies used on fuel tank on aircraft, refers to the protection concept that keeps the oxygen concentration of the ullage space below certain level that can cause the fuel to burn by engines and ensures its safety during the entire flight. It suggested that when the ullage of a fuel tank has the oxygen concentration less than 9%, fire and explosion would not happen even the airplane was attacked by 23 mm caliber bombs. Therefore, for the design of modern aircraft, the regulation of the ullage oxygen concentration is that, the oxygen concentration value is below 9% for military aircraft and is below 12% for commercial ones [5]. Using ultrasonic technology in proposed methodology to eliminate microorganisms in the fuel can be used on aircraft fuel tanks, in the oil refinery or at the airport storage facilities and or in the fuel tanker. Ultrasonic heats up the fuel in the tank, and at the same time it destroys microorganisms. In order to avoid the risk of fuel temperature reaching auto-ignition point, the fuel temperature is monitored continuously, and if it reaches unsafe limits, the controller switch off the ultrasonic. In addition, as a safety, the fuel tank is pressurized with nitrogen before starting ultrasonic, to prevent risk of fuel auto-ignition during ultrasonic operation.

Large transport airplanes fly at very high altitude, where outside air temperature can reach -7°C , and since fuel is stored in wings, then fuel can freeze up and restrict fuel flow to engines. Several aircraft accidents occurred due to fuel freezing at high altitude therefore the proposed ultrasonic methodology, in addition to elimination of microorganisms, it can be used to heat the fuel to safe limit.

Water Contamination

Water accumulate in the fuel tanks, during flight, due to the condensation, as the moist air enters the tank through the fuel vent ports. Water contamination can occur during normal aircraft operation, when aircraft is flying at high altitude. At high altitude the ambient temperature can reach -6°C , in such temperature both the fuel and wing tank structure become extremely cold and as air enters the fuel tank for ventilation, especially in tropical climates, the air is very humid and as it hits the fuel tank structure, it condenses as result water droplets will form. Also during descent, large quantity of outside air enters the fuel tank due to pressure differences between the outside and fuel tank therefore during descent, large amount of air enters fuel tank and as the humid air condenses on the cold fuel tank structure, water is formed. Water mixes with the fuel inside fuel tank. Kerosene also absorbs water from atmosphere [3].

Water can be introduced, also, into the fuel system from deteriorated gas cap seals exposed to rain, or from the supplier's storage tanks and delivery vehicles. Sediment contamination can arise from dirt and dirt entering the tanks during refueling, or from deteriorating rubber fuel tanks or tank sealant [6]. Moist air can enter fuel tanks through aircraft fuel vent ports, located on the bottom surfaces of wing tips, especially air aircraft flies through rainy clouds, and or thunderstorms.

Water can enter aircraft fuel tanks via fuel vent ports during; aircraft washing process if the vent ports are not sealed; aircraft parked at the terminal in a rainy/snowy weather condition, and as aircraft flies through the clouds and thunderstorms, moist enters the tanks through fuel vent ports. Water can enter an aircraft fuel system through leaks in the fuel vents, deteriorated seals, or poorly fitted fuel caps, refueling aircraft during rain or snowstorms, during aircraft wash, by condensation and precipitation, especially if the aircraft fuel tanks are partially filled with fuel. Water can enter an airport storage system through leaks in underground tanks and leaks in the seals of items such as dome covers and floating roofs, etc. (FAA Advisory Circular Number: 20-125, 1985). Updraft (column of rising air) in thunderstorms may contain very large concentrations of water, which could result in engine flameout and or failure of the engine [7]. Therefore, flying through stormy cloud, large amount of water or ice could enter fuel tanks through the fuel vent ports.

Fuel contamination can result in loss of all propulsive power since the problem affects all engines, perhaps the most common source of fuel contamination is water...water in fuel can be undetectable at concentration level of 80 PPM at ground ambient conditions [3].

The water in the fuel can take one of the three forms: dissolved, entrained (suspended) and free water. Dissolved water occurs when a water molecule attaches to a hydrocarbon molecule that the amount-dissolved water in fuel depends on humidity, temperature and chemical constitution of the fuel. As a general guide; the dissolved water in fuel is in parts per millions, however, when warm fuel is cooled, the dissolved water is released and takes the form of either entrained or free water. Any dissolved water in fuel, at low fuel temperature will not form ice because the water molecules are still bonded to the fuel. Dust particles in the fuel, can cause dissolved water to form ice but the amount of ice is very small [1]. Dissolved water is not a problem for aircraft operation, it cannot be removed by filtration, however, if fuel temperature reduces to below zero degrees, it will cause dissolved water to come out of solution as free water which can cause operating problems (FAA Advisory Circular Number: 20-125, 1985). Entrained (suspended) water is the water that is suspended in the fuel as tiny droplets. Entrained water in fuel, when freezes, it forms ice crystals, and since the density of ice crystals is approximately the same as the fuel, the ice crystal stays in suspension and drift within fuel. Ice crystals form around -1°C to -3°C , and as temperature of water is further reduced to 'Critical Icing Temperature' that is between -9°C and -11°C , the ice crystal start to stick to the surroundings. As temperature of water is further reduced to -18°C , the ice crystals start to adhere to each other and they become large, with risk of blocking small orifices. Free water is neither dissolved nor entrained and since they have higher density of fuel, it takes form of droplets or puddles of water lying on the bottom of tank. As free water cool below its freezing point, they form ice [1].

Effect of Water Contamination in Aviation Fuel

Water causes rust and corrosion of iron components thus it forms loose particles of iron oxide, which contributes to fuel nozzle wear and subsequently its failure over a period. Water can lead to premature wear of fuel pumps, which rely on the fuel as source of lubrication properties.

Water in fuel at high altitude freezes and can block the fuel pipeline thus stop or severely restrict the fuel flow to the engine, which can contribute to engine flame out, or even engine shut down during flight [3].

Fuel contamination can result in loss of all propulsive power since the problem affects all engines, perhaps the most common source of fuel contamination is water, and water in fuel can be undetectable at concentration level of 80 PPM at ground ambient conditions [3].

According to NTSB, over the past ten years, ice has been a factor in twenty-four crashes causing the deaths of 138 people [8].

In 1982, ice contributed to the crash of an Air Florida Boeing 737 at Washington National Airport. In 1988, a Continental DC-10 crashed on takeoff because of ice. The fuel in the wings comes in very close proximity to the aircraft skin, and become very cold, especially in cold weather conditions or high altitudes. Thus, the cold fuel acts like a refrigerator, which it cools the outside air and cause frost or ice to form on the wings, therefore the ice can form on the wings when there is no visible moisture [8].

On 11 February 1958, a Boeing B52D crashed in South Dakota, USA due to uncommented reduction in engine power during go-around flight phase. Investigation revealed that the contributing factors were excess water/ice within fuel system. On 26 November 2008, registered N862DA, a Boeing 777-200ER, flying from China to Atlanta in USA, during cruise at 39,000 feet, the right engine suffered reduction of power for 23 minutes. NTSB stated on 11 March 2009, that the fuel oil heat exchanger on the right engine became restricted with ice, hence reducing fuel flow to the engine [9]. During ice accumulation tests using the fuel test rig, the result showed that it is possible for water to turn to ice, and to block the inlet of fuel booster pump, fuel oil heat exchanger and fuel jet pumps (which scavenge water/fuel mixture from bottom of fuel tank and supply it to booster pump) thus restricting fuel flow. Analysis of the ice accumulation tests, showed that by injecting small amount of water and reducing the fuel temperature, ice can be formed around the inside of all fuel pipes, as shown in Figure 1, from the booster pump discharge outlet to the front of the strut [1].

After British Airways Boeing B-777 (G-YMMM) in 17 January 2008, accident, aircraft investigators conducted the snowball tests by introducing water into fuel and cooling the fuel rapidly. The result showed that in about 40 seconds, the water turned into ice crystals reaching the Fuel Oil Heat Exchanger (FOHE), as shown in Figures 2 and 3, restricting the fuel flow [1].

UK Aircraft Accident Investigation Branch, after British Airways Boeing B777-200 ER with registration G-YMMM accident in 17 January 2008, they came up with several safety recommendations, few mentioned below:

Safety Recommendation 2008-047: it recommends the Federal Aviation Administration and European aviation Safety Agency, in conjunction with Boeing and Rolls-Royce to introduce interim measures for the Boeing 777, powered by Trent 800 engines, to reduce the risk of ice formation from water in fuel, which it result in fuel flow restriction to the engine [1].

Safety Recommendation 2009-028: it recommends Boeing and Rolls-Royce to review the aircraft and engine fuel system design, for the Boeing 777, and to develop changes to avoid fuel flow restriction to the engine due to ice formation in the fuel [1].

On 24 June 2009, Boeing and Rolls-Royce introduced a modification to the fuel/oil heat exchanger (FOHE) by redesigning its face such

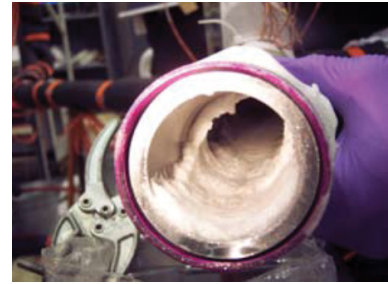

Figure 1: Shows ice build-up inside the fuel pipe when water in fuel forms ice during the experiment, source: Air accident Investigation Branch, 2010.

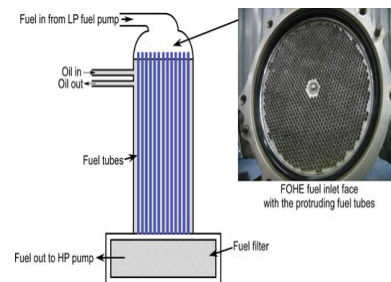

Figure 2: Shows fuel oil heat exchanger (Aircraft Accidents Investigation Branch, 2010).



Figure 3: Shows fuel oil heat exchanger when water in fuel turning into ice crystals and restricting fuel flow source: (Aircraft Accidents Investigation Branch, 2010).

that the fuel heat transfer tubes are flush with the end plate and the inlet clamp removed. This is to enable FOHE to withstand soft ice being released. The two types of fuel heaters commonly used on large transport airplanes. Fuel heaters introduced on large transport airplanes to minimize the effect of fuel icing. These heaters usually use hot engine bleed air or hot engine oil, to heat fuel through a heat exchanger. The heat exchanger using bleed air is located on the spar or in engine pylon area, and the heat exchanger using hot engine oil is located on the engine, and the heat exchanger [1]. However, most of water in fuel tanks take the form of free water and entrained water, which gradually settle on the bottom of the fuel tank. This condition presents the most risks, because, when water temperature reduces to below 0°C, it freezes, and it can block the scavenge jet pumps and block the inlet screen of fuel booster pumps. In addition, result in fuel flow restriction to the engine. Fuel system icing inhibitor is a fuel additive used on some business jets; however, it is not commonly used in large public transport aircraft. It is only effective on undissolved water [1].

Current Water Removal

Aircraft manufacturer states to take regular fuel samples to check for

water contamination, and in some cases, these fuel samples are sent to laboratory for analysis. The laboratory analysis will take three days to check for presence of bacteria causing corrosion. Aircraft maintenance manuals require aircraft maintenance personnel to take fuel samples after each refueling. One of the main disadvantage is time consumption; most aircraft have short turnaround time between 1 to 3 hours.

Current installation of water drain valves at the bottom of the wing requires personnel to manually drain fuel tank. In Airbus A340-300 there are total of 19 drain valves. The drain valve, consists of inner valve, a spring, outer valves, and a spring. By pushing the outer valve with wrench, it pushes the inner valve to open and to drain the water from fuel tank (Airbus A340-300; AMM 28-11-00). However, if the inner valve jams, it will result in fuel leakage, and to replace the defective water drain valve, it requires fuel tank entry, and this will stop the aircraft to fly, because it is time consuming. It requires aircraft to be totally defueled then the fuel tank to be purged with dry air to let the fuel vapors out; in order for personnel to enter the fuel tank and to replace the drain valve. In addition, other disadvantages with water drain valves, is that there is a risk of water freezing around the drain valves, thus it prevents the water to be drained from fuel tanks (Airbus, July 2008). To drain water from all the fuel drain valves, it requires aircraft to be stationary and no fuel pump operation. To drain water from one fuel tank, it can take up to hour, depending upon the size of fuel tank and quantity of water in the tank, therefore, it is very time consuming.

To take a fuel sample before each refuel and to use a biological test kit, available in marketplace. This method has advantages and disadvantages; however, it does not provide a detailed analysis of fuel contamination. The key indicators of fuel contamination observed in drained water from fuel tanks, laboratory analysis and fuel quantity indication fluctuation in the cockpit [10].

Current installation of fuel scavenging system to remove water in fuel tank. Water is heavier than fuel, therefore, it settles in the bottom of the fuel tank. The aircraft fuel scavenging system consists of couple of water scavenge jet pumps, which works on venturi principle. Jet pump shown in Figure 4, it receives motive flow from the main fuel booster pump, and create suction, and then it draws water/fuel mixture from the lowest point in the tank, and fed to the fuel booster pump and supplied to engines. In this method, water/fuel mixture is burned while engine in operation. Tests were conducted using the fuel test rig, and it was established that fuel jet pump can be blocked with ice when water in fuel freezes at high altitude. In addition, foreign objects can block the jet pump. For example, analysis of the jet pump on British Airways, Boeing B777, after the aircraft accident in 17 January 2008 in London Heathrow, showed that one of jet pump was blocked by 6 mm plastic disc [1]. The other disadvantage is that the fuel scavenge system is only effective during the main fuel booster pumps operation, this means that when the aircraft engines are not operating, then the fuel

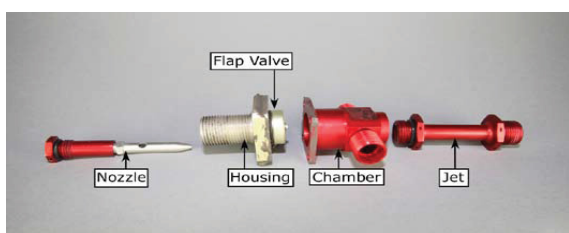

Figure 4: Fuel scavenge jet pump of British Airways (G-YMMM) Boeing B777, the small nozzle can be blocked by ice. Source: (Aircraft Accidents Investigation Branch, 2010).

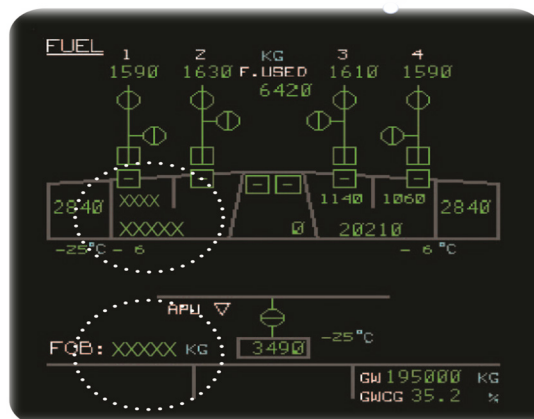

Figure 5: Shows fuel quantity and total fuel on board (FOB) indication for left wing as XXXs (no data) due to microbiological contamination in fuel, Source: (Airbus, 2006).

scavenging system does not operate. This allows humid air to enter the fuel tanks via fuel vent ports and water to accumulate inside fuel tanks, and support microbiological organism.

Modern aircrafts such as Boeing 777, have ultrasonic water detector installed in each fuel tank, and provide a message in the cockpit, if there is water in the fuel tank. The water detector immersed in the fuel, and calculate the time for ultrasonic signal to travel from the transducer and reflected back from an integral end cap to the detector. In case of water presence in fuel, the signal is reflected back sooner. However, ice and air bubbles in the fuel, affect the water detectors and it triggers nuisance water message, and in turn, it leads to perform maintenance action thus result in unnecessary delays. The minimum required for the water detector to generate advisory message is 32 litres of water in the main tank, and 697 litres of water in the center fuel tank. Boeing aircraft manufacture is aware of the nuisance water messages of center fuel tank, generated by the water detectors during aircraft operation [9].

Microbial Contamination

The Fuel Quantity Indication System (FQIS) measures the fuel quantity in the tanks. In addition, the FQIS computes the total fuel on board of aircraft. Such data is used in Airbus A330/A340 fleets for automatic refueling, to shift fuel from one tank to another fuel tank, which is called fuel auto-transfer, in order to control center of gravity. The FQIS utilizes vertical probes located throughout the tanks, to measure fuel quantity [10]. Microbiological contamination of fuel is the major threat to FQIS. Water in proximity of fuel probes, causes the measured fuel capacitance to change, typically, the probes will over read. In some cases, one fuel tank in one wing will read higher with respect to the fuel tank on other wing, thus it indicates to pilot that there is a fuel imbalance. Fuel contaminated with water can cause FQIS to fluctuate or enter into degraded or failed mode. When in the cockpit, no fuel quantity is shown, the data will be removed and shown as (XXX), as in Figure 5 (Airbus Technical Magazine, July 2008). In commercial aircrafts, there is no system which it detects actual fuel leak on fuel tanks, therefore, the current procedure in Airbus A320 Flight Crew Operating Manual (FCOM) is for pilot to monitor the fuel quantity in both wings, and in case of any fuel unbalance greater than certain limits (500 KG), then this indicates possibility of a fuel leak. Then pilot must stop the affected fuel pump and, land as soon as possible to nearest airport [11]. Water contamination in fuel, it causes the FQIS to over read, and in some cases, one fuel tank will over read

with respect to other, thus result in a fuel imbalance situation. This situation could mislead pilot to make unnecessary emergency landing. If the fuel contamination is not treated, it can result in the main engine fuel filter to clog or lead to fuel tank structure corrosion (Figure 6), therefore aircraft manufacturer recommends all operators to include contamination prevention in their maintenance programme, and in case of contamination, a thorough cleaning of fuel tanks is required. Because if the fuel tank; is not thoroughly cleaned, then there is a risk of microbiological contamination to reoccur, thus it will result in more financial impact on the airline and additional future maintenance action [12].

Fuel contamination can result in the fuel filter to clog. When the fuel filter is clogged, the bypass valve open and the differential pressure sensor across the filter brings (trigger) the warning. A fuel filter bypass warning in cockpit may result in delays, as pilot elects to return to ground or divert to other airport along its flight route. Contamination can enter the airplane fuel tanks from fuel uplift or from fuel vent ports [13]. Boeing recommends operators to reduce the chance of microbial growth in fuel tanks, by draining water and by testing for microbes.

Fuel microbial growth can clog fuel filters, causing the airplane fuel quantity indication system to read incorrect values, and eventually cause structural corrosion of the aluminum stringers and wing skin”.

In case of heavy microbiological fuel contamination, aircraft manufacturer states that to use biocide treatment. If the fuel sample shows high biological fuel contamination, then the aircraft maintenance manual states that within 10 days, the aircraft must be defueled, then all fuel tanks must be refueled to maximum capacity with fuel treated with biocide fuel additive at a concentration of 270 PPM by weight. Airbus recommends for aircraft to be on ground for minimum of 72 hours known as (soaking time), to allow the fuel treated with biocide to soak inside fuel tanks. During soaking time, aircraft should not move the engines and APU pumps should not be operated, and no fuel/water drain tests allowed. After soaking time, manufacturer states to replace all the engines and APU fuel filter elements, and further fuel samples to taken after flight to ensure no contamination (Airbus A340-300 Maintenance Manual, Chapter 28, PP 301-307). After biocides treatment, engines or APU consumes the fuel, and biological contamination test must be repeated again within 10 days, however, if high fuel contamination is still present, then aircraft must be defueled, and fuel tank entry is necessary to remove all the traces of contamination from fuel tanks and fuel components. This will result in delays, more costs and effect flight safety if not all traces of contamination is removed.

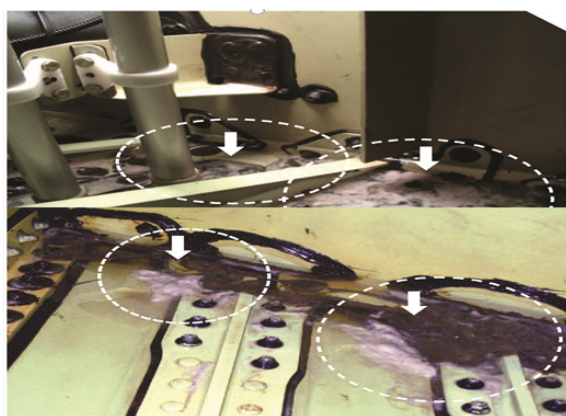

Figure 6: Shows microbiological fuel contamination attached to the tank structure, Source: (Airbus, 2006).

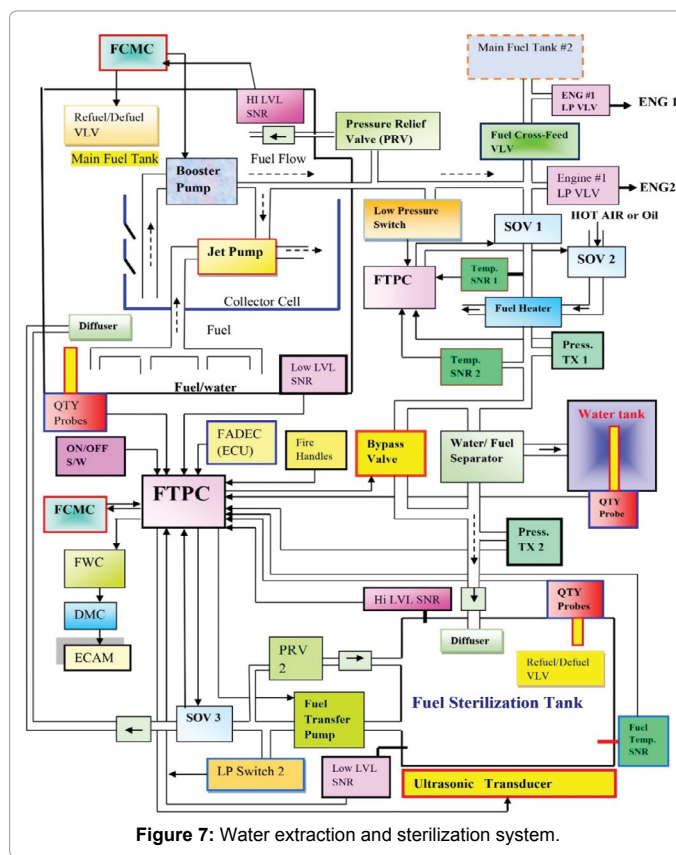

Figure 7: Water extraction and sterilization system.

Water Extraction and Sterilization System

To start an engine, pilot has to select the fuel booster pumps to on position. As soon as pilot move the master fuel lever to on position, the fuel low pressure valve opens and fuel flows to the engine. If fuel water extraction and sterilization is required, then pilot have to select the fuel/water extraction and sterilization switch to on position. With reference to Figure 7, FTSC will command solenoid operated valve (SOV 1) to open, provided there is no inhibition conditions, as shown in figure 8. The SOV 1 position feedback switch sends the signal to the processor (FTSC) that the valve is in open position. Fuel from main fuel tank will flow to the engine, Figure 7, as well as to the water extraction system. The SOV 1 will open, if the fuel cross-feed valve is not in open position, because the fuel cross-feed valve will be selected to open by crew to transfer fuel from one fuel tank to other engine in case of no or low fuel quantity in other the fuel tank. In addition, the fuel cross-feed valve opens to transfer fuel one fuel tank to other fuel tank during ground operation. It also, opens to defuel all fuel tanks on large transport aircrafts. Therefore, under such conditions, the SOV 1 will be close for safety reason and priority given to keep safe operation of the engine. Water extraction and sterilization can start while aircraft is parked (with engines off). By selecting the fuel booster pumps to on in order to transfer fuel to sterilization tank and the personnel should select the water/fuel sterilization system switch to on. Once the fuel in sterilization tank reach full level, the personnel can select the fuel booster pump to off. FTSC can be programmed to perform such functions automatically. Therefore, fuel will be filtered from water and sterilized while aircraft is on ground and waiting for next flight.

Refueling trucks are provided with a fuel filter / separator capable of filtration of water particles about 5 microns in size at rated flow of the

truck (FAA advisory Circular number: 20-125, 1985). However, large transport airplanes do not have water filtration of fuel.

The fuel flows from main tank via SOV 1 to the water/ fuel separator, which it separate water from fuel, and route the water to the water tank, with reference to Figure 7. The extracted water could be dumped overboard via the drain mast located in the tail section of aircraft. Extracted water can be routed to a water storage tank, which is fitted with fuel quantity probe, and when the tank is full, the FTSC generates a message for personnel to drain it. Using water storage tank has the advantage that the operator can determine the efficiency of the water/fuel separator, and it can be used as an indication to replace the water/fuel separator due to malfunction. At higher altitude, water in the fuel could freeze up and block the water/fuel separator. Therefore, the fuel temperature is monitored continuously, and in case of low fuel temperature, FTSC will command the SOV 2, to open to allow hot bleed air from engine or hot engine oil to pass through the fuel heater, which is a heat exchanger. If the fuel temperature rises to beyond the permissible range, FTSC will command shut-off valve (SOV 2) to closes, and hence no fuel heating will occur. In case of fuel heater malfunction, the fuel temperature sensors 1 and 2 will read the same values; hence, FTSC will generate a failure message, for maintenance personnel to take corrective action. In case of fuel/water separator blockage or malfunction, the differential pressure valve opens and the separator is bypassed. The fuel pressure to the inlet and outlet of the separator is continuously monitored, by the fuel pressure transmitter 1 (measure fuel pressure to the separator inlet, and fuel pressure transmitter 2 which measure outlet pressure from the separator) as shown in Figure 7. In addition, in case of the fuel/water separator blockage, there will be a large differential pressure across the separator; therefore, FTSC will command the bypass valve to open. At the same time, FTSC will generate failure message in the cockpit to be shown on ECAM, in order for maintenance personnel to replace the separator. As water extracted from fuel, it enters sterilization tank until the tank is full. More than one fuel/water separator can be used to increase fuel flow entering the sterilization tank, and fuel will stay in sterilization tank about ten minutes, where it is exposed to ultrasonic sound waves, in order to kill the microorganisms, then sterilized fuel is transferred to the main tank. The cycle repeats until all fuel sterilized, provided the sterilization inhibition logics, are not available. FCMC on large transport airplanes such as Airbus A330/340 series, it measures the fuel quantity in the fuel tanks, controls fuel transfer from center tank to inner fuel tanks. In addition, transfer fuel from outer wing fuel tank into inner fuel tank. The reason is to keep fuel in main inner fuel tanks most of the duration of the flight, to minimize stress by reducing wing binding due to lift force fluctuation. FCMC automatically transfer fuel forward from trim tank to center or inner main tanks or transfer fuel aft from center or inner tank to the trim fuel tank, in order to control the center of the aircraft gravity. In proposed design, it supplies data to the FTSC.

The FTSC can be programmed so that the fuel can be exposed to ultrasonic radiation for different period. For example, if the fuel temperature is near freezing temperature, then ultrasonic can be used for longer time to heat up the fuel, thus prevent fuel freezing at very cold temperatures. The ultrasonic transducer controlled by the FTSC, will transmit ultrasound waves, when the fuel quantity in the sterilization tank is reaches high level, as sensed by the level sensor. The ultrasonic transducers are located outside the sterilization fuel tank at the bottom surface. The fuel quantity data in sterilization tank is send to FTSC. When the fuel is subject to required sound waves at particular power and frequency, then FTSC will command the SOV 3 to open and the transfer pump to transfer fuel to the main tank, provided that main

fuel tank is not full. The transfer pump stops when the fuel quantity in the sterilization reaches to low level. There are two transfer pumps, one pump is active, and second one acts as standby in case of a failure. If the active transfer pump fails, the low-pressure sensor 2 will sense it, and FTSC will switch off the active pump, and command the second transfer pump to operate. The transfer pump will stop operation, if low fuel quantity sensed in the sterilization tank or in case of the pump low-pressure. In case of SOV 3 failure in close position or transfer pump over pressure condition, the pressure relief valve (PRV 2) operates, and dump excess fuel pressure back to the sterilization tank, to avoid overheating of the transfer pump. When fuel in the sterilization reaches full level, FTSC will command the SOV 1 to close. The transfer pump operates only if SOV 3 is in open position, because if the valve is close and pump is operating, it result in pump overheat and damages the pump.

The fuel water extraction and sterilization operates, when pilot manually selects the system to ON position. This is to ensure that in case of malfunction or emergency condition during the flight, pilot can switch off the system at any time, and thus the fuel in the sterilization tank will be transfer to the main fuel tank if the main fuel tank is not full. This is part of the Inhibition logics in proposed methodology shown in Figure 8. For illustration, in case of low fuel quantity in the main fuel tank, or during takeoff / go-around flight phases, where maximum engine thrust is required, hence, more fuel flow to the engine is required. Then the fuel water extraction & sterilization circuit will be inhibited. The Engine Control Unit (FADEC), which controls the operation of the engine in Airbus A340s, it sends signals to the FTSC to stop the circuit fuel/water extraction and sterilization, by commanding SOV 1 to close. In case of engine fire, the circuit stops the extraction and sterilization system automatically, to avoid any fuel pump operation during critical situation, when pilot operate the fire handle to shut down engine and extinguish fire. In addition, in case of fuel jettison selected by pilot, the circuit stops fuel water extraction and sterilization; thus, fuel in the sterilization tank is transfer to the main fuel tank for fuel to be dumped overboard via jettison valves. As part of safety logics in the processor, the fuel /water extraction and sterilization inhibited to operate under certain conditions, as shown in Figure 8. The water extraction and sterilization stops and any fuel in the sterilization tank will be transfer to the main fuel tank, if the fuel temperature in the sterilization tank is greater than safe limit. As fuel subjected to ultrasonic, its temperature increases, and kerosene temperature should not reach auto-ignition point of 22°C. The other conditions include low fuel quantity in the main tank, because during flight, engine draws fuel from main tanks, and if the main tank has low fuel quantity then the extraction and sterilization have to stop. Moreover, to transfer fuel from sterilization tank to main tank, in order to stop engine starving from fuel (SOV 1 closes, and SOV 3 opens and the pump transfer fuel to the main tank). During jettison, aircraft have to dump excess fuel to avoid

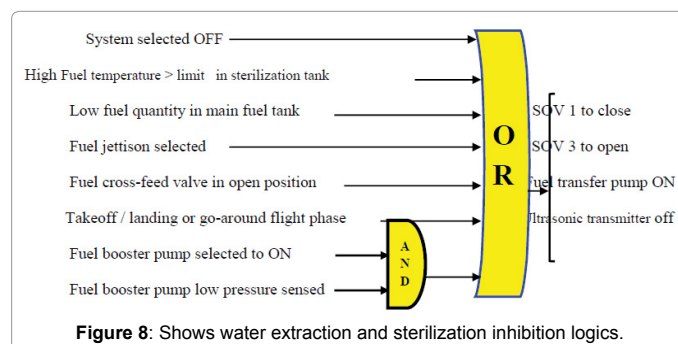

Figure 8: Shows water extraction and sterilization inhibition logics.

heavy landing in emergency, therefore the system stops, and transfer any fuel stored in the sterilization tank to main tank. Then the jettison pump in the main tank draw fuel from main tanks and dump the fuel overboard via the jettison valve located near wing tip. As part of safety logic, if the fuel pumps in main tank are operating and low fuel pressure sensed, then the extraction and sterilization system stop (SOV 1 close to stop fuel to enter sterilization tank, ultrasonic switched off, SOV 3 opens for fuel to transfer to main tank), and fuel transfer pump operate to transfer fuel in sterilization tank to main tank. Fuel booster pump require fuel for lubrication and cooling purposes, and if pump operate at low fuel pressure due to low fuel quantity in main tank, then there is risk of the booster pump overheating which in turn can result into sparks, therefore, for safety reason, the fuel in the sterilization tank will be transferred to the main tank.

Fuel transfer pump operate provided there is fuel in the sterilization tank and the main fuel tank is not full. In addition, for safety reason; as shown in Figure 9, for the transfer pump to operate, apart from the inhibition logics; the SOV 3 should be open to avoid excessive pressure buildup of fuel in the pipe, which can result overheating of the pump. The pressure relief valve will operate to relief the excessive load on the pump in case of the SOV 3 failure. Also, if the transfer pump low pressure switch 2 is sensing low pressure, as part of safety, to avoid overheat of the pump which may result in fuel tank explosion, then the transfer pump will not operate. All fuel booster pumps recommended by aircraft manufacturers to be switch off manually in case of pump low-pressure warning. When fuel enters sterilization tank to full level, SOV 1 closes, fuel subjected to ultrasonic (10 minutes), then SOV 3 commanded to open and fuel transfer pump operates.

Ultrasonic transducer or transducers operating at different frequencies could be located at the bottom of the sterilization tank, and generate sound waves at different frequencies, in order to kill different desirable bacteria and sterilize the fuel. Thus, in order to save energy, the ultrasonic transducers could be programmed to operate under certain conditions, for example; only on ground when the refueling process is complete. In author design, the sterilization tank could be aircraft actual center fuel tank or additional fuel tank in the aircraft. Most large transports such as Airbus A310/A320/A330/340s and Boeing B777 have center fuel tank and or additional fuel tank for longer range. Thus, it minimizes installing a new tank on aircraft for fuel sterilization purposes. In Airbus fleet, fuel in the center tank automatically transferred to the wings inner fuel tanks during engine operation, when fuel quantity is less than two tons in the main inner fuel tank. This is to minimize over bending of the wings during flight. FTSC could be programmed to consider different scenario.

The circuit (FTSC) could be programmed to operate, as soon as aircraft refueling is complete and while aircraft is on ground with engine off. This will disinfect the fuel as quickly as possible, thus minimize microorganisms to build up inside fuel tanks. The processor can be programmed to operate when engine is operating during ground and

flight. Fuel sterilization and water extraction system can be selected to off at any time by flight crew due to any reason. If there is no fuel in the sterilization tank, and engine not operating, the crew have to select the fuel booster pumps (Manual mode) in the main tanks to on position, in order to transfer fuel to the sterilization tank. Alternatively, FTSC can be programmed to automatically operate the fuel booster (Auto mode) in the main tank, if there is no pump low pressure and no low fuel quantity in the main fuel tank. In such case, fuel will be delivered to the sterilization tank via the water/fuel separator. When the fuel in the sterilization tank is full, the FTSC will send a signal to SOV 1 to close and fuel will be subjected to ultrasonic for suitable time then it is transferred to the main tank. When fuel quantity in sterilization reaches low level, the transfer pump stops, and SOV 1 open to let fresh fuel to enter the sterilization tank. This cycle repeats until all fuel quantity in all fuel tanks are sterilized.

The water/fuel separator, which separates water from fuel, could be Separ SWK-2000; currently the filter is used to filter diesel fuel at the fuel rate of 7,800 liters per hour and on ships, fast boats and yacht. Fuel enters the filter input port, where a van chamber, creating centrifugal rotating motion to the fuel. The centrifugal rotation causes the heavier particles such as dirt and water droplets to fall down onto the bowl. As fuel comes out from the first centrifuge chamber (vane), it hit the side of the bowl and fuel continues to spin. Fuel flows via second vane centrifuge stage, which further forces the fuel to spin in a different direction where smaller dirt's and water droplets fall down onto bowl. Last stage the fuel enter the water resistant paper elements where further fine dirt's and water is extracted [14]. In the proposed methodology; two fuel/water separators can be used to increase the fuel flow rate to the sterilization tank; however, in case of drain valve bowl at bottom of the separator, the drain valve will be connected to the reservoir to store the filtered water from fuel, and to be drained by maintenance person when it reaches full or near full quantity.

Water Accumulation Inside Fuel Tanks on Ground

The fuel tank venting system keeps the air pressure in the fuel tanks near to atmospheric pressure, to prevent large difference in the pressures to exist, which could affect the fuel tank structure. However, contaminants such as ice, water, sand, debris can enter fuel tanks via the fuel ports, especially if aircraft is parked at the terminal in severe weather conditions for several days or hours. In proposed methodology, the fuel vent ports can be installed with a solenoid valve or a torque motor valve, which closes the fuel vent to atmosphere if aircraft is ground and that there is no refuel/defueling, no engine/APU operation. In case of its failure, the valve can manually be moved to open position.

How to Eliminate the Risk of Fuel Auto-Ignition

Following the TWA flight 800 crash in 1996, the US National Transportation Safety Board (NSTB) attributed the accident to the explosion of the center fuel tank. This accident led to the introduction of new regulations by the Federal Airworthiness Authority (FAA) to reduce ignition sources inside fuel tank. Currently, most modern aircrafts have center fuel tank inert system, which uses nitrogen generated by Air Separator Module (ASM) which is based upon hollow-fiber technology, to extract nitrogen from the supplied air [15]. Auto-ignition point for kerosene is about 210 C. Using ultrasonic technology in proposed methodology to eliminate microorganisms in the fuel can be used on aircraft fuel tanks, in the oil refinery or at the airport storage facilities and or in the fuel tanker. Ultrasonic heats up the fuel in the tank, and at the same time it destroys microorganisms. In order to avoid the risk of fuel temperature reaching auto-ignition point, firstly the fuel

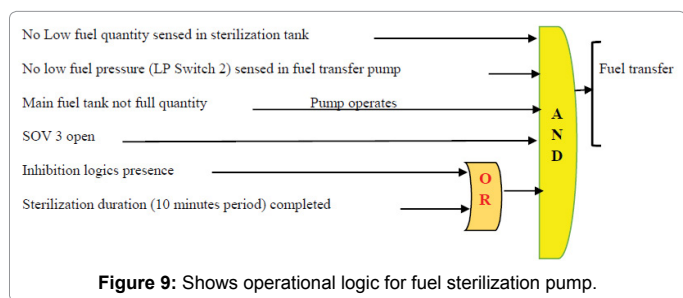

Figure 9: Shows operational logic for fuel sterilization pump.

temperature is monitored continuously, and when it reaches unsafe limit, the processor inhibit the operation of ultrasonic system. In addition, as part of safety, the tank is pressurized with nitrogen to reduce the oxygen level to acceptable level in order to inhibit fuel ignition. It suggested that when the ullage of a fuel tank has the oxygen concentration less than 9%, fire and explosion would not happen. Figure 10, illustrates that the proposed methodology can be used on the fuel tanker (which delivers fuel to the aircraft). The tank ullage is pressurized with nitrogen to acceptable value, avoiding large differential pressure between ambient and the tank ullage pressures, which in turn it depends on fuel tank material and strength. Ambient air is pressurized by air compressor, and supplied to the Air Separator Module, which extract nitrogen from air and supply it to the tank. The ullage pressure is monitored and when it reaches certain limit, the controller stops the pressurization process (the air compressor stops and SOV) closes. Should ullage pressure increase to unsafe limit, to avoid excessive large differential pressure, the pressure relief valve opens and ventilate the tank. When the fuel tanker is pressurized, the ultrasonic process starts.

The Main Advantages of the Fuel Water Extraction and Sterilization

It prevents or minimize water accumulation in the fuel tanks by extracting water from fuel and eliminating the microorganisms in fuel tanks, which could result into aircraft structure corrosion, fuel tank sealant damage and, leading to fuel leak and consequently fire, and fuel tank explosion.

Microbiological growth buildup on the fuel quantity probes inside fuel tanks, can lead to error in fuel quantity indication and ultrasonic can eliminate microbes growth.

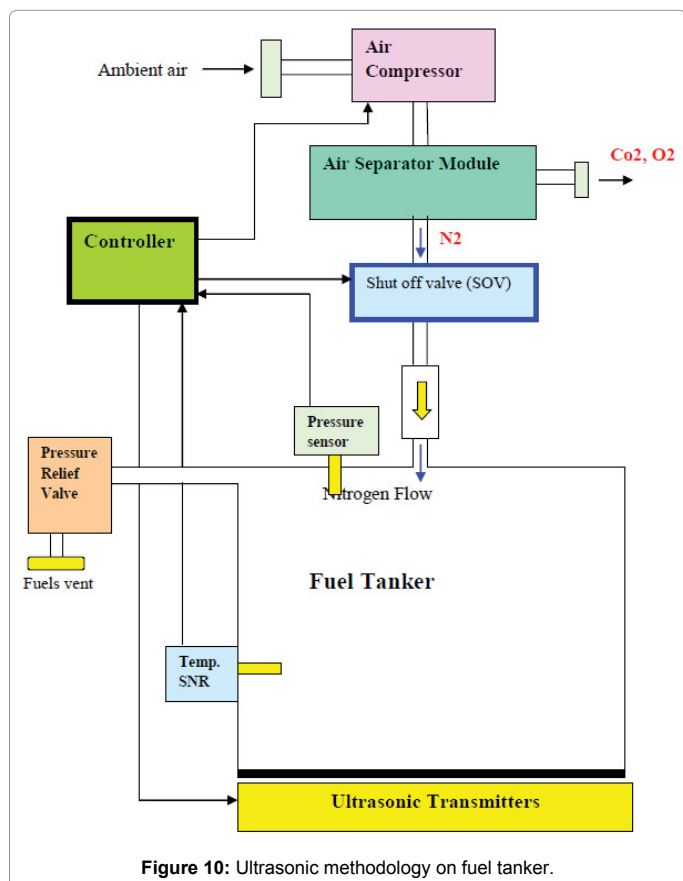

Figure 10: Ultrasonic methodology on fuel tanker.

Ultrasonic can remove contaminants from crevices and blind holes on the part that normal cleaning methods cannot do it [16]. Sound waves have the ability to clean metals, as well as plastic parts. If it is used in fuel tanks, it can remove rust, debris, grease, dirt from fuel pumps, sensors, fuel quantity probes, fuel pipes, fuel valves, and clean fuel tanks, etc. Ultrasonic waves increase the fuel temperature, and it minimize water in fuel icing up and blocking the fuel pipe lines, scavenge jet pumps, fuel booster inlet screen, fuel filters, and fuel/oil heat exchanger thus minimize the risk of engine thrust reduction at critical flight phases. In proposed design, (existing fuel tanks, valves and fuel pumps could be used to achieve the goal) hence simple in design and not expensive. Ultrasonic is very effective in killing the bacteria and fungus accumulation inside fuel tanks, and it minimizes fuel quantity indication error. It increases flight safety.

How to overcome the challenges in proposed methodology such as:

Energy consumption: it can be minimized by programming the processor to switch on the ultrasonic transducer only for specific period of 15 to 20 minutes at certain flight phases. For example, after aircraft fuel tank refueling and or during cruise phase or after landing with engine shutdown, the system can be operated to sterilize the fuel and extract any water. Using several transducers in the fuel tanks increases the weight. In order to reduce weight issue, nanotechnology can be used to reduce the size and weight of the ultrasonic transducers. For example, nanotechnology can design and create tiny products, which are a thousand times thinner than a human hair. Nanotechnology has made many tiny devices and sensors that are available in the market, designing products, which are tiny in size, less weight, cleaner, and stronger, etc [17].

Difficulty in installing ultrasonic transducers in wing fuel tanks, ultrasonic transducer can be designed in form of a very thin film (sheet), just like aircraft skin metal sheets, which could be located below the fuel tanks. Alternate way, is to install ultrasonic transducer in center or additional center fuel tanks, which are located in the cargo compartment. Fuel enters the center fuel tank and sterilized, then fuel is transferred to the wing fuel tanks.

Ultrasonic Experiment

The purpose of the experiments is to establish the followings; firstly, to establish that the fuel sample will not ignite if subjected to sound waves over a period of time. Secondly, to determine if fuel temperature increases when subjected to sound waves. Thirdly, to calculate the average temperature rise of fuel sample over time, if fuel sample subjected to ultrasonic of 42 KHz 50 watts. Finally, to determine if subjecting the fuel sample to ultrasonic located outside the tank (not in contact with fuel) can kill the bacteria in the fuel. Microbiological contaminated fuel subjected to ultrasonic to different times, in order to determine the effectively of the ultrasonic.

Microbiological contaminated Fuel/water mixture (600 millilitres) poured into the ultrasonic device, which has a stainless-steel tank with 600 millilitres capacity. The ultrasonic device operated with power supply input of 220 volts (50 watts) and frequency of 42 Khz. The contaminated fuel samples subjected to ultrasonic (not in direct contact with fuel) for 20 minutes then the sample was poured into the disinfected glass jar to be checked in laboratory and, the result showed that microorganisms were eliminated. In addition, the second and third microbiological contaminated samples subjected to 25 and 30 minutes ultrasonic, and at the laboratory, results showed no microorganisms. Ultrasonic transmitter was not in direct contact with the fuel sample.

The fuel temperatures monitored during ultrasonic process, Figure 11, shows the temperature rise of the fuel sample (600 millilitres) after being subjected to ultrasonic at frequency of 42 Khz 50 watts. The fuel samples sent to the microbiological analysis laboratory for analysis of the fuel samples. The microbiological analysis included quantitative checks on the number of aerobic bacteria, fungal colonies presence, and whether or not the corrosion causing bacteria are presence. The fuel samples analysis took three days and the result was satisfactory (free from all bacteria).

Analysis of the Experiments

In the proposed methodology, ultrasonic is used to destroy microorganism in the fuel. The ultrasonic is not in direct contact with the fuel and hence eliminating the source of ignition inside fuel tank. Experiments carried out and result showed that ultrasonic was effective in destroying the microorganism. The proposed methodology can be adopted on aircraft. In addition, Ultrasonic sterilization in proposed methodology can be used at the airport fuel storage facilities, to supply sterilized fuel to the aircraft before departure. Or the fuel tankers at the airport can adopt the proposed method to sterilize fuel then supply it to the aircraft before departure.

The use of ultrasound irradiation for disinfection has been extensively studied. Laboratory experiments to disinfect water and water waste have been used, and the experiments were involved using different methods. One method was using ultrasonic probe being immersed into relatively small volumes of liquid, and other methods were involved using ultrasonic transducers located outside the tank, not in direct contact with the liquid, known as ultrasonic bath. In ultrasonic plug flow method, the ultrasonic transducer is located inside the tank, in contact with the liquid. Both the ultrasonic bath and plug flow methods used to disinfect larger volumes of liquid. The result in brief, showed that if ultrasonic irradiation used at certain intensity (power) and at certain frequency over a period, it would eliminate the microorganisms. Ultrasound as it moves through the liquid, it create an effect known as cavitation, which is the rapid formation and collapse of microscopic bubbles that kills the microorganisms. As the microscopic bubbles collapse, it releases energy, thus it increases the temperature of the water. Three factors are important in elimination of microorganisms in the liquid, and they are ultrasonic power level, frequency and duration [18]. Ultrasound waves can be used to remove light corrosion (rust), oil, grease, debris, and dirt from metal or plastic parts. Ultrasonic cleaners are widely available in the market, which uses sound waves in water solution to clean items such as tools, coins, watches, jewelry, metal parts, etc. Ultrasonic is an effective way to clean



Figure 11: Shows fuel sample in the ultrasonic device in the microbiological fuel laboratory.

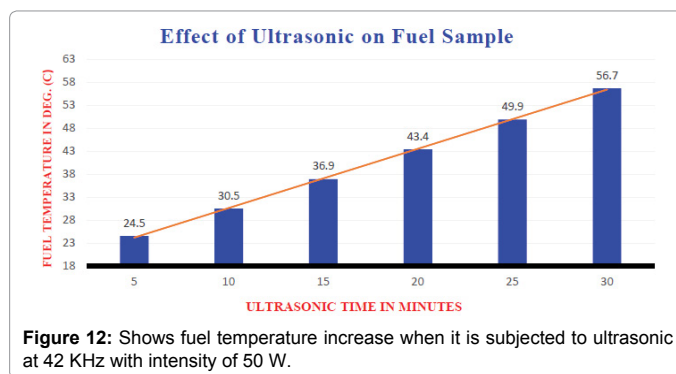

Figure 12: Shows fuel temperature increase when it is subjected to ultrasonic at 42 KHz with intensity of 50 W.

the parts because it penetrates blind holes, cracks and cavities [19]. Ultrasound propagation in water will heat up water slightly, depending upon the power level [20].

During the experiment, the fuel temperature increased as it was subjected to ultrasonic. Figure 12, the chart shows the fuel sample temperature was at 18 C and when it subjected to 5 minutes of ultrasonic, the fuel temperature increased to 24.2 C, and when subjected to 10 minutes its temperature increased to 30.5 C, etc. The amount of fuel temperature rise subjected to ultrasonic, depends to certain degree to amount of water in the fuel sample, However, in general, the following observed during the experiments: firstly, subjecting the fuel samples for maximum of 30 minutes to ultrasonic, it did not result into fire or explosion. Secondly, after switching off the ultrasonic device, all the microscopic bubbles disappeared instantly within two seconds. Thirdly, ultrasonic of ten minutes found very effective in killing the bacteria in the fuel. Fourthly, for every five minutes of fuel samples (600 millilitres) subjected to ultrasonic with 50 W power intensity, the fuel/water sample temperature increased by average of about 6.2 C. Finally, the amount of fuel temperature rise depends upon the power and duration of ultrasonic [21-36].

Ultrasonic can heat up fuel, and if fuel temperature increases to auto-ignition point for kerosene (220 C), fuel burns without any source of ignition. Such risk exists in all current large transport airplanes, because fuel is heated to prevent water to freeze up at high altitude thus prevent fuel restriction and the engine flame out. In large transport airplanes, several heat exchangers are used for such purpose. In proposed methodology, the risk is eliminated by monitoring the temperature of fuel. And if it reaches to unsafe limit, the processor will turn off the ultrasonic transmission device. In case of any malfunction, the crew can manually select off the entire system. The fuel temperature of all fuel tanks including sterilization tank will be shown in cockpit for pilots to monitor, and when it reaches the unsafe limit, the text message appears in the screen for pilot to take corrective action. Pilot can select the sterilization system to off at any time.

Discussion

Fuel contamination with microorganism can result into fuel tank corrosion, and result in fuel leak, thus in turn, it can lead to fire or an explosion. In addition, it results in fuel quantity malfunction, fuel filter blockage and result in fuel restriction to the engine. Using ultrasonic to eliminate microorganisms in the proposed methodology can be adopted on aircraft, at the oil refinery or airport fuel storage facilities or in the fuel tanker. Using ultrasonic on aircraft to sterilize fuel, have its advantages that it sterilizes the fuel tanks, and removes dirt/ deposits from fuel quantity probes, fuel pumps and valves etc. and increase their operation life.

It is not common to use ultrasonic to sterilize fuel, however, ultrasonic has been used in many applications. For illustration, ultrasonic is used in dentistry to disinfect teeth, to clean and remove rust from car parts, to clean jewelry, watches, semiconductors, CDs, etc. When fluid is subjected to sound waves, microscopic bubbles (cavitations) produced. The bubbles upon collapse destroy bacteria, fungus, algae and release energy, which increases the temperature of the fluid. The bubbles arriving at the surface, it disappears. The cavitation increases with the frequency of sound waves. Ultrasonic is effective way of cleaning the parts because microscopic bubbles can reach the cavities and holes, where it is cleaned effectively. Using ultrasonic to disinfection fuel from microorganisms, also, it can be used to heat up the fuel to acceptable safe level. In large transport aircrafts, fuel is heated through heat exchangers by using very hot engine oil, and hot bleed air. Large transport airplanes fly at very high altitude, where outside air temperature can reach -70 C, and since fuel is stored in wings, then fuel can freeze up and restrict fuel flow to engines. Several aircraft accidents occurred due to fuel freezing at high altitude, and ultrasonic can be used as an alternate solution ice formation in fuel. Ultrasonic can be used to heat the fuel to safe limit. The fuel temperature in the sterilization tank is measured continuously, and if the fuel temperature rises to certain unsafe limit, the temperature sensor in the fuel tank send signal to the processor to stop ultrasonic propagation, and fuel is transferred to the main fuel tanks. Heavy microorganism fuel contamination will result in aircraft to be grounded for 3 days, because it requires the fuel tanks to be defueled, purged, cleaned, and refueled with fuel treated by biocide for 72 hours as per aircraft manufacturer procedures on Airbus and Boeing fleets. Resulting in flight cancellation and loss of earnings. Therefore, the proposed methodology can be used to prevent or reduce such effect.

Proposed ultrasonic methodology can be used on aircraft, in the oil refinery or at the airport storage facilities and or in the fuel tanker. Ultrasonic heats the fuel slowly, and the risk of auto-ignition is eliminated by pressurize the tank with nitrogen and monitoring the fuel temperature continuously.

The Boeing 777 airliner and the Lockheed Martin F-22 fighter jet are the aircraft types, which use ultrasonic to measure fuel quantity inside the fuel tanks (Langton et al, 2009, P328). Therefore, it is not uncommon not to use ultrasonic inside fuel tanks.

Experiments were conducted by subjecting the fuel samples (600 millilitres) to ultrasonic at frequency of 42 KHz (50 watts) over period of time. Ultrasonic transmitter was not in direct contact with the fuel sample. Experiment was conducted to determine that subjecting fuel to ultrasonic; it does cause fire or explosion. The fuel temperatures monitored during ultrasonic process, and the result of study showed that ultrasonic did not cause fire or explosion, however, the fuel temperature increased by about 6.2 C for every five minutes of ultrasonic propagation. The fuel samples sent to the microbiological analysis laboratory for analysis of the fuel samples, and the result showed ultrasonic was effective in destroying the bacteria in the fuel.

Water contamination in aviation fuel, can freeze at low temperature, and turns to ice, and it can block inlet of fuel booster pumps inlet ports, fuel scavenge pumps, fuel oil heat exchanger, therefore restricting fuel flow to the engine and, result in reduction in engine power. Microbiological contamination of fuel is the major threat to aircraft safety. Water in proximity of fuel probes, causes the measured fuel capacitance to change, typically, the probes will over read. In some cases, one fuel tank in one wing will read higher with respect to the fuel tank on other wing, thus it indicates to pilot that there is a fuel imbalance. Fuel contaminated with water can cause Fuel quantity

indication system (FQIS) to fluctuate or enter into degraded or failed mode, where in the cockpit, no fuel quantity will be shown, the data will be removed and; shown as (XXX). In addition, Fuel contamination due to microbiological contamination can result in fuel tank structure corrosion, and consequently lead to fuel leak. Fuel leak on hot engine surfaces or hot brakes and result into fire or explosion.

Water in fuel continue to contribute to aircraft incidents and accidents and, at times, fatal accidents. A review of NTSB briefs of aircraft accidents states that the 114 aircraft accidents was due to fuel contamination with water, occurred between January 7, 1980, and September 11, 1981 (FAA Advisory Circular Number: 20-125, 1985).

Current aircraft system design includes scavenge jet pump system and fuel drain valves. The scavenge jet pump system operates as long as booster pump is operating and supply fuel to the engine, in order to burn the fuel/water mixture at the bottom of the fuel tank. However, this will not eliminate the water issue in fuel tanks because water accumulate inside fuel tanks by humid air entering the tanks through fuel vent ports while the aircraft is parked and the booster pumps are not operating. The current alternate method of draining water from fuel tanks through drain valves, it takes long time and most aircrafts have short turn-around time, so it is done when aircraft enters hangar checks for maintenance.

In the proposed methodology, extract water from fuel by using fuel/water separator and route it to the drain tank. In addition, fuel is disinfected and heated by using ultrasonic technology. Fuel temperature is monitored continuously, and it should not reach very high temperature because it increases the risk of ignition. Therefore, when fuel temperature increases to unsafe limit, ultrasonic propagation stopped. In theory, fuel temperature should not be low to allow water in fuel to freeze up, and fuel temperature should not reach high temperature. Most of water in fuel tanks take the form of free water and entrained water, which gradually settle on the bottom of the fuel tank. This condition presents the most risks, because, when water temperature reduces to below 0°C, it freezes, and it can block the scavenge jet pumps and block the inlet screen of fuel booster pumps, thus result in fuel flow reduction to engine. In current design, fuel heaters are used to prevent fuel icing, however, they are located on the pylon or on the engine, and have no effect on the water accumulated on the bottom of the fuel tanks, which freeze up at low temperature. Therefore, fuel heaters do not solve the issue, and aircraft maintenance engineers have to manually drain water accumulated on the bottom of the tank, through the drain valves. This is time consuming and in case of malfunction due to deteriorated O-ring, it can result in fuel leakage, and to replace it, it requires fuel tank to be defueled, purged, and fuel tank entry. UK Aircraft Accident Investigation Branch, after British Airways Boeing B777-200 ER with registration G-YMMM accident in 17 January 2008, due to water in fuel freeze up, they came up with several safety recommendations. Safety Recommendation 2009-028 states it recommends Boeing and Rolls-Royce to review the aircraft and engine fuel system design for the Boeing 777, and to develop changes to avoid fuel flow restriction to the engine due to ice formation in the fuel.

Conclusion

In the proposed methodology, the water/Fuel separator type is Separ SWK-2000 filter, which currently is used on ships, fast boats and yacht to filter diesel fuel at the rate of 7,800 liters per hour. Fuel enters the filter input port, where a van chamber, creating centrifugal rotating motion to the fuel. The centrifugal rotation causes the heavier particles such as dirt and water droplets to fall down onto the bowl. Therefore, similar

principle can be used to filter water from kerosene on large transport airplanes. In proposed design, the water/fuel separator is not installed in the main fuel supply, but in fuel flow path going to the sterilization fuel tank. Therefore, the fuel from main tank is supplied to sterilization tank through the water/fuel separator. Fuel stay in the sterilization tank for a suitable time where fuel is subjected to ultrasonic at certain power level, the higher the power of sound waves propagation, the sooner the disinfection (killing of the bacteria in the fuel). Ultrasonic transducers are located outside the sterilization tank and are not exposed to fuel.

The main advantages of the fuel water extraction and sterilization, includes that the water is extracted from the fuel, and fuel is disinfected and heated by using ultrasonic. In addition, ultrasonic minimizes the microbiological organism build up on the fuel quantity probes and inside fuel tanks. Therefore, it reduces the risk of error in fuel tank quantity indication, and reduces risk of fuel tank corrosion. Ultrasonic waves increase the fuel temperature, and it minimize water in fuel icing up and blocking the fuel pipe lines, fuel filters, and fuel/oil heat exchanger thus minimize the risk of engine thrust reduction at critical flight phases.

References

1. Air Accidents Investigation Branch (2010) Report on the Accident to Boeing 777-236ER, G-YMMM, At London Heathrow Airport on 17 January 2008", Report No: AAIB 1/2010, UK.
2. Boeing (2015) Boeing 777 Aircraft Maintenance Manual Chapter, USA
3. Roy L, Martin C, Martin H, Lonnie R (2009) Aircraft fuel systems. John Wiley & Sons Ltd, UK.
4. FAA advisory circular (1985) Water in aviation fuels. US Department of Transportation, USA.
5. Yan C, Xueqin B, Guiping L, Bing S, Yu Z, et al (2014) Experimental study of an aircraft fuel tank inerting system. Chinese J Aeronautics, Beihang University, Beijing China.
6. FAA (2011) Airplane flying handbook. FAA-8033-3A, (3rd edn), Skyhorse Publication, USA.
7. FAA (2013) Thunderstorms advisory circular. AC NO: 00-24C, Department of Transportation, USA.
8. Captain Power-Waters B (2008) Is it safe? why flying commercial airliner is still a risky business and what can be done about it. USA.
9. Griffioen H (2012) Air crash investigations eye of the needle the crash of British airways flight 38, UK.
10. Airbus Technical Magazine (2006) Flight Airworthiness Support Technology FAST 38. Airbus Customer Services, France.
11. Airbus A320 (2015) Flight crew operating manual. Airbus Technical Publication, France.
12. Airbus (2006) Flight airworthiness support technology fast 38. Airbus Customer Services, France.
13. Boeing (2008) Boeing aero magazine, Quarter 03, Boeing publication, USA.
14. Separ Filter (2016) SWK-2000-10 duplex, clear bowl America, USA.
15. Bernie M, Roy L (2011) Gas turbine propulsion systems. John Wiley & Sons Ltd, UK.
16. Lee M, StuartNaddeo V, Cesaro D, Mantzavinos D, Fatta-Kassinou D, Belgiorno N (2014) Water and wastewater disinfection by ultrasound irradiation a critical review. *Global NEST J* 16: 561-577.
17. Lee S (1989) Dictionary of composite materials technology. Technomic Publication, USA.
18. Berube DM (2006) Nano-hype: The truth behind the nanotechnology buzz. Prometheus Books, USA.
19. McEvily AJ (2013) Metal failures mechanism, analysis, prevention (2nd edn), John Wiley & Sons, Canada.
20. Povey JWM (1997) Ultrasonic techniques for fluids characterization, UK.
21. Airbus (2008) Flight airworthiness support technology fast 42. Airbus Technical Magazine Airbus Customer Services, France.
22. Abeyratne R (2012) Strategic issues in air transport legal, economic and technical aspects. Springer, London, UK.
23. Casadeval TJ (1991) Volcanic ash and aviation safety: Proceedings of the first international symposium on volcanic ash and aviation safety. *US Geo Sur Bull* 2047, USA.
24. Daily Mail News (2010) Not our finest hour! Planes grounded, thousands of festive holidays ruined, roads ungritted, drivers stranded for hours and all because it snowed, UK.
25. The Daily Galaxy (2012) Super volcanic eruptions with the potential to end civilizations-disturbing new discovery.
26. FAA (2008) International de/anti-icing chapter. US Department of Transport, USA.
27. Milton K (2013) Advantages and disadvantages of circuit breaker and fuses.
28. Mason TJ (1999) Studies on the 'kerosene fungus' *Cladosporium resinae* (Lindau) de vries-part i. the problem of microbial contamination of aviation fuels. *Advances in Sonochemistry*, Victoria University of Wellington, New Zealand.
29. Moir I, Seabridge A (2008) Aircraft systems: Mechanical, electrical and avionics subsystems integration. 3rd edn, John Wiley & Sons Ltd, England.
30. National Research Council (1997) Aviation fuels with improved fire safety: A proceedings. The National Academy of Sciences, USA.
31. Vladimir RA, Martin UA (2003) Lightning physics and effects, Cambridge University Press, UK.
32. Swamy VY, Das SN, Parida KM, Misra VN (2002) Management of industrial effluents and wastes. New Delhi, Applied Publishers PVT. Ltd, India.
33. Sheridan JE, Nelson J, Tan LY (1971) Studies on the kerosene fungus *Cladosporium Resinae* (Lindau) De Vries- Part I. the problem of microbial contamination of aviation fuels. *J Biological Society*, New Zealand.
34. TwistedSifter (2013) 15 Volcanic eruptions seen from space.
35. Uman AM, Rakov AV (2003) The interaction of lightning with airborne vehicles. *Progress in Aerospace Sciences Elsevier science Ltd, USA* 39: 61-81.
36. Tingyue Gu, Dake Xu (2013) Why are some microbe's corrosive and some not? NACE International Publication, USA.