

Design and Analysis Aircraft Nose and Nose Landing Gear

Rajesh A and Abhay BT*

Department of Mechanical Engineering, New Horizon College of Engineering, Bangalore, India

Abstract

Tri-cycle arrangement landing gear is extensively used as it is simple; convenient both structurally as well as aerodynamically. Though it is advantageous over other configuration it has its own drawbacks. Factors like its weight drag, sudden application of load, acoustics, fatigue etc tend to slow down its performance and life. Among main landing gear and nose landing gear; the former carries about 85% of total weight of aircraft and latter carries around 12-15% of weight. The nose landing gear is also a source of noise and its effect is prominent when compared to main landing gear. In this project the executive jet aircraft are studied thoroughly and a nose landing gear similar to those of executive jets is modeled using CATIA. The same geometry is imported to ANSYS ICEM and flow on the body is analyzed for different angle of attack. Pressure variation, temperature, density and velocity distribution around the body is noted and then Coefficient for Lift and Drag are plotted against angle of attack for obtained results. It is also important to check the strength and stiffness of designed landing gear. Hence using ANSYS APDL and Explicit; Static structural and Impact test has been carried out for designed geometry. Stress distribution and deformation was noted for two distinct materials such as steel and aluminum alloy and primary results of acoustics has been compared with the available data.

Keywords: Angle of attack; Deformation; Flow over body; Coefficient of lift; Coefficient of drag Impact landing; Nose landing gear; Stress distribution; Acoustics

Introduction

Landing gear [1] is one of the important parts of an aircraft; often referred [2] to as undercarriage. Landing gear is a structure which is installed on the aircraft for the purpose to support the weight of the aircraft while it is on the ground and also allows the aircraft for smooth maneuver such as takeoff and landing. Landing gear also provides mobility to the aircraft on ground or water. It is capable of reaching the largest local load on the plane. The landing gear's main function is to control the rate of compression/extension and to prevent further damage to itself as well as other parts of an aircraft when a load is applied. Loads can be either static or dynamic in both cases the structure must withstand applied loads and deformation and continue to do its purpose. Among the available configuration the most common type of landing gear arrangement is tri-cycle arrangement. Considering the nose landing gear configuration of a tri cycle the stress distribution and deformation [3] is noted for an executive jet aircraft for applied loads.

Nomenclature of Landing Gear

Landing gears are located on the under carriage of aircraft. The front landing is called as nose landing gear while main landing gear [4] is located on rear side of aircraft. Nose landing gear consists of actuators to retract and extension; drag brace to lock the pins metering pin extension; trunnion; rotation lock pins; aft braces; oleo cylinder; oleo piston; brake assembly; tires and wheels which is shown in Figure 1.

Design and Operational Requirement

Operational Requirement showed in Table 1

$$H_{CG} = \Delta H_{clear} + \frac{D_{prop}}{2} \quad (1)$$

$$C = s/b \quad (2)$$

$$= 1.2 + 1.9$$

$$= 3.1$$

$$b = \sqrt{s \times AR} \quad (3)$$

$$= \sqrt{60 \times 12}$$

$$= 26.883m$$

$$\bar{C} = \frac{S}{b} \quad (4)$$

$$= \frac{60}{26.883}$$

$$= 2.236$$

$$V_R = 1.1V_s \quad (5)$$

$$= 48.1 \text{ m/s}$$

$$D_{To} = \frac{1}{2} \rho v^2 S C_{DTo} \quad (6)$$

$$= 6267.4 \text{ N}$$

Based on the design requirement and as per the need of the project the nose landing gear dimensions are altered and are designed in

Maximum Takeoff weight [5]	18000 Kg
Static load acting	17650 N
Impact load acting	67032 N

Table 1: Operational Requirement.

*Corresponding author: Abhay BT, Department of Mechanical Engineering, New Horizon College of Engineering, Bangalore, India, Tel: 9686908369; E-mail: abhayt123@gmail.com

Received September 29, 2015; Accepted October 14, 2015; Published October 24, 2015

Citation: Rajesh A, Abhay BT (2015) Design and Analysis Aircraft Nose and Nose Landing Gear. J Aeronaut Aerospace Eng 4: 144. doi:10.4172/2168-9792.1000144

Copyright: © 2015 Rajesh A, et al. This is an open-access article distributed under the terms of the Creative Commons Attribution License, which permits unrestricted use, distribution, and reproduction in any medium, provided the original author and source are credited.

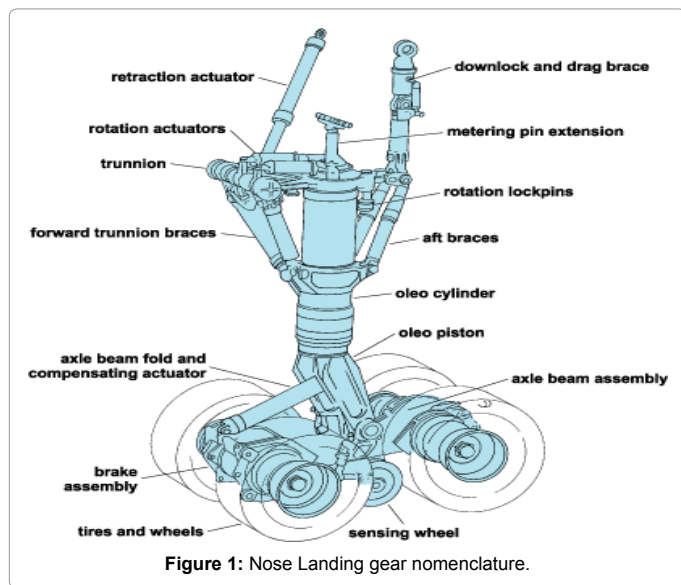

Figure 1: Nose Landing gear nomenclature.

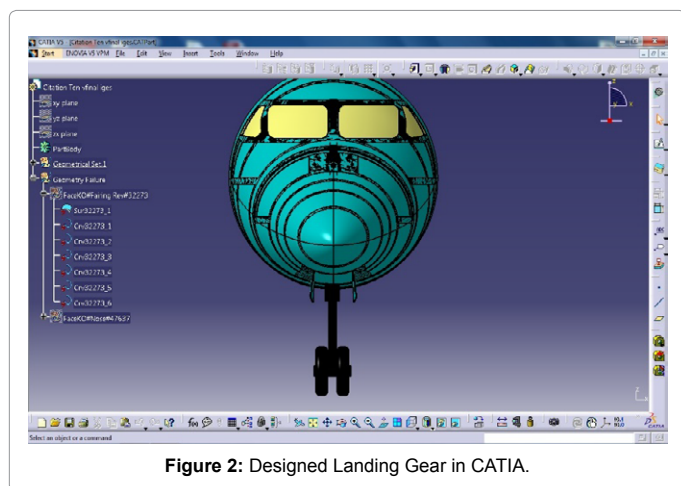

Figure 2: Designed Landing Gear in CATIA.

CATIA V5 R19. Since only nose landing gear is concern of this project nose landing gear is designed along with nose cone as shown in Figure 2.

In order to analyze the fluid flow, the geometry is spilt into number of elements. If the number of elements is high the accuracy of results is high [5]. TRIA surface mesh is used to mesh the geometry. Auto mesh is used to mesh the curved surface and edges.

The geometry is subjected to flow analysis. It is done by assigning flow properties to the geometry within the domain. The body was tested for five different conditions by varying its angle of attack from -5° to 15° with the equal increments of 5° and by maintaining flow speed constant at 0.2 mach.

The domain properties are as such that the outlet from the geometry is 5 times when compared to inlet. The flow is assumed to be continuous which is also non buoyant. The static temperature assigned is 300 K. It is also found that there are 468848 nodes and the number of elements in the domain is 1599260. The meshed geometry shown in Figure 3.

The landing gear is checked for its stability and stiffness by assigning it two material properties Aluminum alloy and Structural

steel [6]. The material properties of steel and aluminum alloy are given in below Table 2.

Results and Discussion

A. Flow analysis-pressure contour

From Figure 4a; a flow analysis has been carried out for the landing gear assembly and nose cone. The geometry is placed in the domain and fluid is allowed to flow over aircraft portion with a Mach number of 0.2 with an angle of attack of -5° . Variation of pressure is obtained for a range of -10742.89 Pa to 3364.05 Pa. Pressure distributions at 0° angle of attack is explained in Figure 4b. The maximum pressure variation is 3333.33 Pa. There is an increase in pressure distribution with the increase in angle of attack. Similar analysis is carried for 5° , 10° and 15° angle of attack as given in Figures 4c-4e respectively. In all the cases it

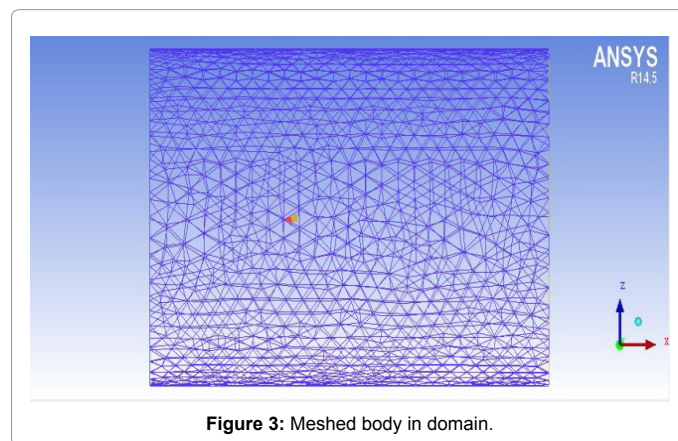

Figure 3: Meshed body in domain.

Properties	Aluminum 2024	Steel
Density (g/cm ³)	2.27	7.85
Coefficient of Thermal expansion (10 ⁻⁶ /°C)	22.8	0.12

Table 2: Material properties.

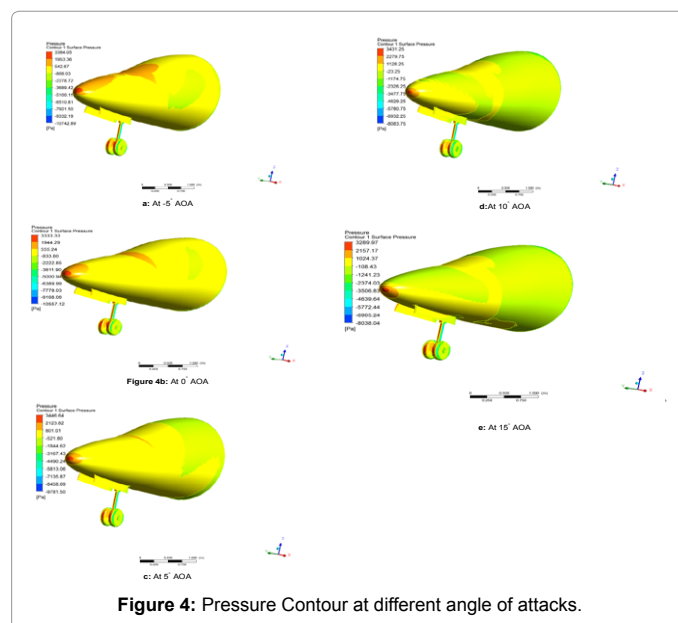

Figure 4: Pressure Contour at different angle of attacks.

is noticed that the maximum pressure acts on front portion of landing gear and nose cone.

From the pressure plots using dynamic equations, coefficient of lift and drag can be calculated and are tabulated in Table 3.

Using the values from Table 3 coefficient of lift and drag values are plotted against angle of attack.

Graph for C_L v/s Angle of attack is shown in Figure 5. It is known that with the increase in angle of attack lift coefficient increases and after reaching a certain angle it tends to decrease which is known as stall angle. From the Figure 5 at 15° angle of attack there is higher lift coefficient which would fall down if the angle of attack is increased further.

Figure 6 is a graph for C_D v/s Angle of attack. At an angle of attack -5° greater amount of drag is experienced by landing gear. With the increase in angle of attack from 0 to 15° drag reduces gradually to minimum value because thrust is more than drag.

V (m/s)	AOA (deg)	C_D	C_L	L/D
68	-5	1.0181	-0.083	-0.0815
68	0	0.9801	0.0094	0.0096
68	5	0.8989	0.0998	0.1111
68	10	0.8215	0.1814	0.2208
68	15	0.7969	0.2242	0.2813

Table 3: Lift and Drag Coefficient.

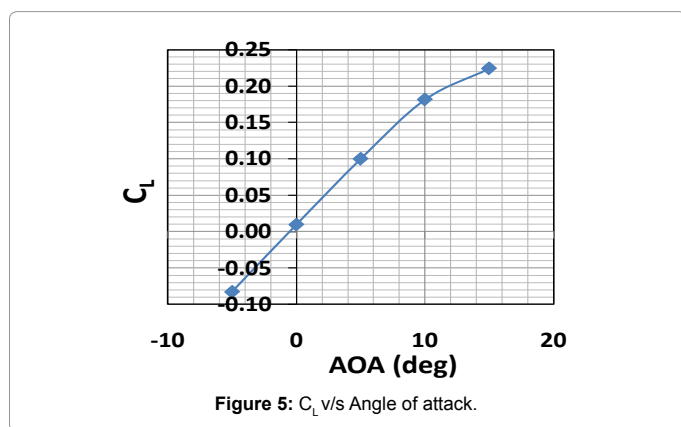

Figure 5: C_L v/s Angle of attack.

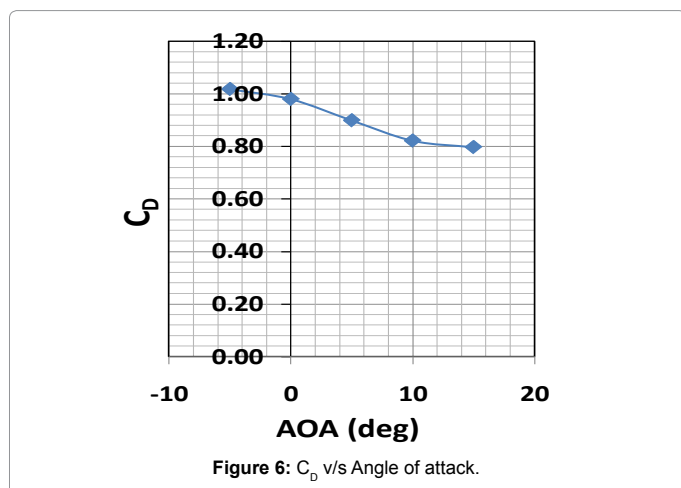

Figure 6: C_D v/s Angle of attack.

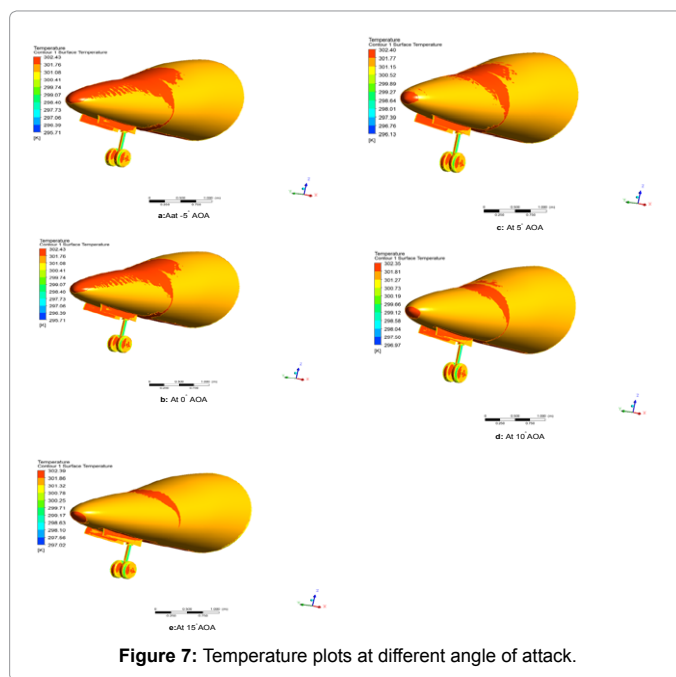

Figure 7: Temperature plots at different angle of attack.

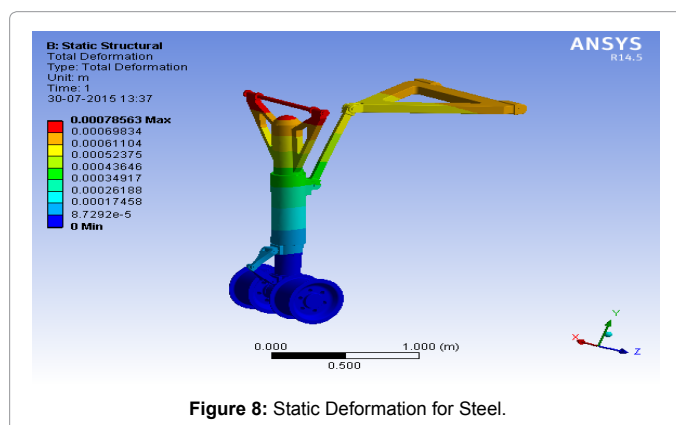

Figure 8: Static Deformation for Steel.

B. Flow analysis –temperature contour

Temperature plots for geometry subjected to flow analysis at mach 0.2 are given in Figure 7. Figure 7a-7e shows geometry at -5° , 0° , 5° , 10° and 15° . In all the cases there is a slight variation on temperature for changing angles and maximum temperature is found at the tip of nose cone and front portion of landing gear.

C. Mechanical analysis

The landing gear assembly has undergone a deformation, when a constant load is applied on the assembly which is at static condition. From Figure 8 maximum deformation of 0.78 mm which is indicated in red color region, and a minimum deformation of 0.000087 mm as shown in blue color region for applied loads. And landing gear assembly is suggested to be safe for a given material and load.

The landing gear assembly has undergone a deformation, when the aircrafts lands on hard runway. An impact load is induced on landing gear which is then transferred to axle and then to strut. From Figure 9 maximum deformations of 4.1 mm which is indicated in red color

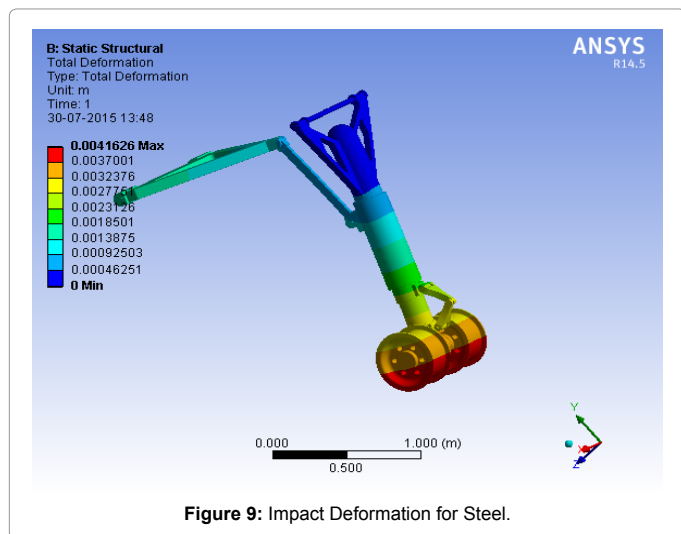

Material	Max Von-Mesis Stress (M Pa)	Max Deformation (Mm)
Steel	15.9	0.78
Aluminum Alloy	12.9	2.1

Table 4: Static Analysis results.

Material	Max Von-Mesis stress (MPa)	Max Deformation (mm)
Steel	82.6	4.1
Aluminum Alloy	65.7	10.96

Table 5: Impact Analysis results.

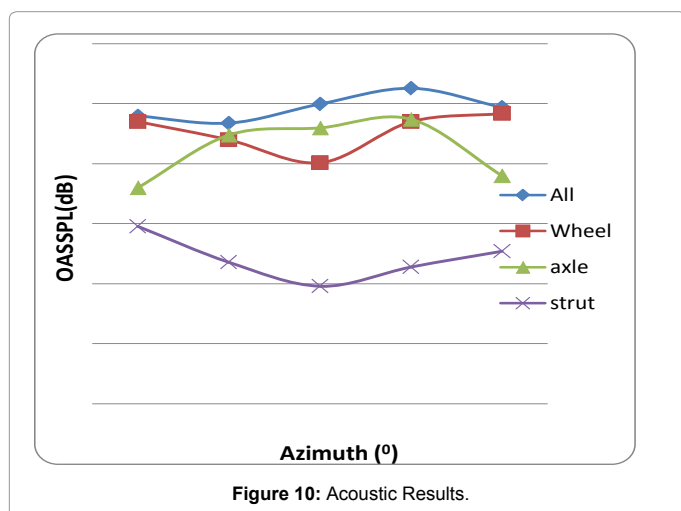

region, and a minimum deformation of 0.46 mm as shown in blue color region for applied loads. And landing gear assembly is suggested to be safe for a given material and load.

Table 4 explains the results of static analysis. The maximum deformation occurs in case of aluminum alloy and a maximum stress distribution is for steel.

During impact test at a given loading condition a maximum deformation occurs for aluminum alloy and stress distribution is maximum in case of steel which is tabulated in Table 5.

D. Aero acoustic results

An initial approach has been carried out to study the noise generated [7] by landing gear by dwelling its surface. The obtained results were of noise in terms of frequency and azimuth angle. It was compared with the available data [8] which closely matched with the result which is given in Figure 10.

Conclusion

CFD analysis has been carried out to study flow around nose landing gear and nose cone, where the flow has been considered into 3 regions on nose landing gear and nose cone namely upper region flow, mid region flow and lower region flow. The upper region flow has its effect on strut while mid region flow effected axle and slightly on wheel. The effect of lower region flow was experienced on wheel.

Sudden application of load deforms the structure. The static deformation and stress distribution are tabulated in Table 4 and impact deformation and stress distribution are tabulated in Table 5.

Stress and deformation value which is obtained for applied loads on structure are found to be within design range and hence the nose landing gear is suggested to be safe.

A possible solution to reduce landing gear noise is streamlining the flow field through the use of fairings. However, streamlining of the entire landing gear structure is difficult due to its size and function (wheels must rotate, brakes require cooling) and a more complicated weight trade-off analysis becomes necessary to determine potential benefits.

References

1. Niu MCY (1989) Airframe structural design. Practical design information and data on Aircraft structures Lockheed Aeronautical systems company, Burbank, California, Conmilit Press ltd Chapter1.
2. Antonio A. Aircraft Classifications. Trani Associate Professor Department of Aeronautical Engineering Virginia Tech.
3. Ganorkar K, Deshbhratar V (2014) Design optimization of Landing Gear of an Aircraft – a review IOSR Journal of Mechanical and Civil Engineering (IOSR-JMCE) 01-04.
4. Megson THG. "Aircraft Structures for engineering students. (3rdedn).
5. Nguyen TD (2010) Finite Element Analysis of a Nose Gear During Landing. UNF Theses and Dissertations Paper 215.
6. Raymer DP. Aircraft Design. A conceptual approach, Conceptual research corporation Sylmar, California. Chapter 11.
7. Gaikwad AV, Sambhe RU, Ghawade PS (2013) Modeling and Analysis of aircraft landing gear : experimental approach, International Journal of Science and Research (IJSR) 2: 366-369.
8. Liu W. Numerical Investigation of Landing Gear Noise, Airbus Noise Technology Center, University of Southampton.