

“Comparison of Extracorporeal Shock Wave Lithotripsy versus Ureteroscopy Holmium Laser Lithotripsy in the Management of Ureteral Stones: A Cost-effectiveness Analysis”

Alberto Budia^{1*}, Vicent Caballer², David Vivas², Daniel López-Acon³, Maria Angeles³, Jose Antonio Diez³, Pilar Bahilo³ and Marta Trassiera³

¹Hospital Universitari i Politecnic La Fe Valencia, Valencia, Spain

²Tarazona Economics, Research Centre for Health Economics and Management, Universitat Politècnica de Valencia, Spain

³Medicine-urologist, Endourology and Lithotripsy Unit, La Fe University and Polytechnic Hospital, Valencia, Spain

Abstract

Objective: To determine the better cost-effective treatment strategy for ureteral stones in a health district of Eastern Spain.

Methods: A total of 180 patients were treated between June 2012 and December 2013 for ureteral stones using two different strategies (SWL as initial treatment and URS as rescue technique vs URS and laser lithotripsy (up to 2 procedures). We performed an economic evaluation through a cost effectiveness analysis comparing costs and outcome. We performed a differentiating model in patients with lithiasis less than 1 cm or equal to or larger than 1 cm. The effectiveness parameter was the stone free rate (SFR), defined as the absence of lithiasis fragments or the presence of clinically insignificant residual fragments (CIRFs) - less than 3 mm at the 3 month follow up. A decision tree was developed and a Monte Carlo simulation was performed to establish uncertainty.

Results: The SWL as first line was equally or more effective and cheaper than URS as first line of treatment for ureteral stones regardless of location or size. The overall cost for SWL (plus URS as second line) was 1,445,86 € and its SFR was 99.7%, and 2,369,21 and 97.62% for URS group. After the Montecarlo sensitivity analysis, the SWL showed dominance or cost-effectiveness in the vast majority of times, for each position and size.

Conclusions: SWL as first line of treatment was more efficient in terms of cost effectiveness than first line URS with Ho: YAG laser lithotripsy for ureteral stones. Given its level of stone clearance, a non-invasive, outpatient based treatment like lithotripsy should remain the first-line treatment option for ureteral stones.

Keywords: Extracorporeal shock wave lithotripsy; Ureteroscopy; Ureteral Lithiasis; Cost-effectiveness; Monte Carlo simulation

Introduction

The optimal treatments of ureteral stones are yet controversial. Although ureteral stones are known to fragment less effectively than renal stones, shockwave lithotripsy (ESWL) has remained the preferred treatment method because of its minimally invasive nature. However the advances in the design of the ureteroscopes have greatly impacted the management of ureteric stones. The introduction of small-caliber semirigid and flexible ureteroscopes, as well as reliable laser technology and the production of more robust flexible instruments have further expanded the indications for endoscopic intervention. These advances have improved the ureteroscopy stone-free rate and decreased the risk of complications. However, the magnitude and rate of introduction and the acceptance of new technology are major determinants of total healthcare costs [1,2]. In the context of limited expenditure on public health and overloaded national medical insurance, the urologist should find out the most cost-effective option to offer the patients best clinical outcome. There is an important gap in knowledge of this aspect in clinical practice.

The purpose of this study was determining the better cost-effective treatment strategy for ureteral stones in Spanish medical setting.

Material and Methods

From June 2012 and December 2013, 201 a prospective non-randomized study was carry on. A total of 201 consecutive patients (180 valid) with ureteral radiopaque calculi were treated with two different treatment strategies in a University hospital by two experienced urologist at our institution. A total of 21 patients were excluded for loss to follow up or non-completion of protocol designed:

ESWL Group (95 patients): ESWL as initial technique and URSL in case of unsuccessful treatment.

URSL Group (85 patients): Holmium Laser URSL as initial technique and a rescue URSL in case of unsuccessful treatment.

Patients with the following conditions were excluded: Patients younger than 14 years, ureteral size stone higher than 2 cm, more than one stone, pregnancy, uncontrolled urinary tract infection, pyonephrosis, sepsis, renal insufficiency with serum creatinine greater than 3.0 mg/dL, hemorrhagic diathesis, important skeletal deformities, history of pelvic surgery or irradiation or open ureterolithotomy for treatment of the same side ureteral stones.

An intravenous urography or enhanced or non enhanced CT scan was performed for all cases before treatment. Antibiotics treated urinary infections preoperatively. A sterile urine culture was obtained in all the cases before the surgery. Patients' demographic parameters, stone feature, hospital stay, treatment outcome, per-operative complications and medical costs were addressed and compared between the two

***Corresponding author:** Alberto Budia, Hospital Universitari i Politecnic La Fe Valencia, Valencia, Spain, Tel: 34650189297; E-mail: alberto.budia@hotmail.com

Received May 29, 2016; **Accepted** August 02, 2016; **Published** August 10, 2016

Citation: Budia A, Caballer V, Vivas D, Acon DL, Angeles M, et al. (2016) “Comparison of Extracorporeal Shock Wave Lithotripsy versus Ureteroscopy Holmium Laser Lithotripsy in the Management of Ureteral Stones: A Cost-effectiveness Analysis”. Med Surg Urol 5: 168. doi: [10.4172/2168-9857.1000168](https://doi.org/10.4172/2168-9857.1000168)

Copyright: © 2016 Budia A, et al. This is an open-access article distributed under the terms of the Creative Commons Attribution License, which permits unrestricted use, distribution, and reproduction in any medium, provided the original author and source are credited.

groups. Before surgery all patients signed an informed consent form and the approval of the hospital ethical committee was obtained.

The assignment to treatment arm was performed according to the patient's decision, after being adequately informed of the two initial treatment options and current recommendations in clinical guidelines. Each group was categorized according to the size of the stone treated (more or less than 1 cm).

ESWL technique

The ESWL treatment was performed under analgesia with meperidine using a third generation electromagnetic lithotripter (Siemens Lithoskop, shockwave system Pulso, Erlangen, Germany). The treatment was performed on an outpatient basis. The shockwave system had an adjustable energy level (in 38 steps from 0.1 to 8) with a focal pressure (P+) from 8.9 MPa to 75.3 MPa. The shockwave energy at 12 mm ranged from 8 mJ to 117 mJ. The maximum focal width was 12 mm and the maximum penetration depth was 16 cm. Treatment was performed with the patient supine and the shockwave head in under table position. In all patients, X-ray was used for stone localization during ESWL treatment. The shock frequency was 120 min. During one treatment session a median of 5.473 (DE 1.735.75) shockwaves were administered unless the stone was defragmented before. Treatment variables (administered number of shockwave, total applied energy) were recorded for each treatment. To assess therapy outcome, X-ray and US examination was usually performed 7 days after ESWL. The therapy was regarded as successful and the patients as stone free, when no more treatable stones were seen (no stone or stone < 3 mm). Re-treatment was performed in cases of residual stones of > 3 mm until a maximum of four sessions. If residual stones persisted after four sessions, an ureteroscopy was performed. If the problem was not resolved with the first intervention, the patient will undergo to a second ureteroscopy. Complete stone clearance was assessed at three months follow up.

URSL technique

In all procedures a 0.035-inch guide-wire was coiled at the renal pelvis, followed by 6.5 Fr semirigid ureteroscopy (Karl Storz GmbH, Tuttlingen, Germany). Laser Lithotripsy unit (Stonelight[®] Holmium Laser System, AMS Inc, Minnetonka, MN, USA) was set at 0.7-1 J energy pulses and 8 to 10 Hz frequency over a 550 µm laser fiber. If the ureteral access was not possible with a semirigid device, a flexible ureteroscope was used (Flex-XTM flexible ureteroscope, 7.5 Fr × 6000 mm; Karl Storz GmbH, Tuttlingen, Germany) with a 275 µm laser fiber). Procedure ended when no fragment remained in the whole ureter or residual fragments were estimated that all would pass spontaneous (fragment size less than 2 mm using de 1 mm wide guire as the referent). An open double-J stent and urethral Foley catheter were left *in situ*. The urethral catheter was removed after 24 hours and discharged. The double J catheter was removed after 10-15 days. To assess therapy outcome, X-ray was usually performed 15 days after URSL. The therapy was regarded as successful and the patient as stone free, when no more treatable stones were seen (no stone or stone < 3 mm). Re-treatment (rescue ureteroscopy) was performed in cases of residual stones of > 3 mm without spontaneous passage until a maximum of four weeks after removing double-J stent. Complete stone clearance was assessed at three months follow up.

Outcomes measure

The treatment results of the two different strategies were compared with the stone free rate (SFR), defined as the absence of lithiasis fragments or the presence of clinically insignificant residual fragments

(CIRFs) - less than 3 mm - at the 3 month follow up. This was determined by kidney-ureter-bladder X-ray or non-contrast enhanced computerized tomography. The rate of complications was performed by monitoring immediate and post-operative complications for each technique. The Clavien-Dindo classification was used for categorization and analysis. The complications included to develop the analysis were those that required hospitalization or unplanned ancillary procedures.

Costs measure

In this study, we calculated the overall hospitalization cost, and the overall postoperative laboratory and radiology test cost for both techniques. The hospitalization cost included the hospital stay, anesthesia, procedure, pharmacy, supplies, disposable materials, stents and catheters. In addition, the postoperative visit cost was also recorded. The data of the global expenditure were extracted from the economic information service hospital and are shown in Tables 1 and 2.

Modeling

An economic evaluation through a cost effectiveness analysis (CEA) was performed comparing costs and outcome [3,4]. This is a systematic method of comparing two or more alternative programs by measuring the costs and consequences (health outcomes) of each [5]. The cost was

	Unit Cost	Average Number Per Patient	Total Cost Per Patient	Total Cost (%)	Average Cost Per Eswl Session
ESWL	335.78	1.93	648.06	62.6	335.78
Consultations	39.75	3.04	120.84	11.7	62.61
Urgencies	170.34	0.15	25.551	2.5	13.24
Hospital stays (Adverse Events)	417.57	0.06	25.05	2.4	12.98
JJ Withdrawal	101	0.09	9.57	0.9	4.96
RX	28.31	2.67	75.59	7.3	39.16
Ecography	37.41	1.32	49.38	4.8	25.59
Computer Tomography without contrast	18.68	0.09	1.68	0.2	0.87
IV Urography	440	0.18	79.20	7.7	41.04
Total			1034.92	100.0	536.23

Table 1: ESWL cost analysis.

	Unit Cost	Average Number Per Patient	Total Cost Per Patient	Total Cost (%)	Average Cost Per Ursl Session
Ursl	1900.13	1.03	1,957.13	85.5	1900.13
Consultations	39.75	1.77	70.36	3.1	68.31
Urgencies	170.34	0.09	15.33	0.7	14.88
Hospital Stays (Adverse Events)	417.57	0.19	79.34	3.5	77.03
Jj Withdrawal	101	0.74	74.74	3.3	72.56
Xray	28.31	1.67	47.28	2.1	45.90
Ecography	37.41	0.56	20.95	0.9	20.34
Computer Tomography Without Contrast	18.68	0.27	5.04	0.2	4.90
Iv Urography	440	0.04	17.60	0.8	17.09
Total			2,287.77	100.0	2,221.14

Table 2: URSL cost analysis.

compiled from economic information of hospital and electronic health records (EHR) and calculated from the initial procedure, subsequent procedures, radiographs, and visits. The study was conducted following the economic costs established by the Regional Health Department (*Conselleria de Sanitat*), who is managing public health in our region.

The total cost of a lithotripsy session was 536.26 €, while for an ureteroscopy amounts to 2221.14 €, representing almost the cost of 6 sessions of lithotripsy. A decision tree [6,7] was modeled for the two alternatives, ESWL and first line URSL. From our database we obtained the probabilities of treatment success for each technique. We calculated probabilities of success- in the case of ESWL for 1 to 4 sessions, for alternative two URSL after ESWL failure in any of the 4 sessions. In the URSL group a limit of two procedures. For both alternatives the probability and costs of major and minor complications was also estimated. The payoff for each group is measured as the of free stone patients rate. Using this model, we estimated the incremental cost effectiveness ratio (ICER) [5]. This ratio compares the costs (incremental costs) and outcomes (incremental effect) from ESWL vs. URSL

$$\Delta C = C_{ESWL} - C_{URSL}$$

$$\Delta E = E_{ESWL} - E_{URSL}$$

$$ICER = \Delta C \div \Delta E$$

A decision tree analysis was designed to discriminate by lithiasis location (ureter lumbar, iliac and pelvic) and size (less than 1 cm or equal to or larger than 1 cm). For the iliac ureteral stones, we analyzed without stratification by size due to the small size of the sample. Finally, we conducted a Monte Carlo simulation for a probabilistic sensitivity analysis [6,8,9]. The procedure to generate sample distribution for ICER was as follows: One sample of costs (C) and health effects (E) from the distribution of costs and effects from ESWL: CESWL and ESWL, and one sample of cost and effects from the distribution of costs and effects of URSL: CURS and EURSL were taken. CURSL - CESWL divided by EURSL-ESWL, and then gave the sample estimate of the incremental CER. This process was repeated a large number of times (1,000 in our case) to give a vector of sample estimate that is the empirical sampling distribution of the incremental CER statistic (β distribution parameter was assumed). When the patient has not stone free after undergoing one of the two treatments, the salvage technique was laparoscopy. The cost of this surgery is 5,000 euros, so this was the threshold of cost effectiveness [10] chosen for the model (5,000 € per patient stone free).

Statistical analysis

Assuming a SFR with ESWL Group of 81% and an expected rate of nearly 94% with URSL Group, the sample size for each group was calculated as 79 (power>80%) with a type I error rate<0.05.

Chi-square statistics were calculated for categorical variables with the Fischer exact test used to calculate P value, with continuous variables being tested with the Student T. P values were two-sided, and <0.05 was statistically significant.

Results

The patient characteristics and comparison between groups, are shown in Table 3. Both groups were comparable except for the variables sex, mean age and stone location, which showed statistically significant differences. The average age was higher in the Group B (URSL) and males were treated mostly with ESWL.

The global analysis of the SFR between therapeutic modality initially elected, regardless rescue techniques, showed greater effectiveness of

URS in the treatment of ureteral stones. This effectiveness was superior when we evaluated according to the size at all locations except in ureteral lumbar lithiasis (equal to or larger than one centimeter) and iliac ureteral stones (Table 4).

A decision tree analysis was built for every location and size stone and it is shown in Figures 1-5. The ESWL as first treatment line (and URSL as second line treatment if ESWL failed) were dominant in all cases despite location and size stone versus URSL as first option of treatment. The Monte Carlo probabilistic sensitivity analysis showed dominance of ESWL as a first line treatment in 100% of cases for the lumbar ureter stones lesser than 1 cm and 99.9% in stones larger than 1 cm. In case of pelvic ureteral lithiasis less than 1 cm, ESWL as initial treatment was dominant in 97,1% and non-cost-effective in 2.9%. If the lithiasis was equal to or larger than 1 cm the dominance was 94.1% and non-cost-effectiveness in 5.6% of cases. In iliac position, ESWL as first line treatment showed a dominance of 84.6% was cost-effective in 3.7% and non-cost-effective in 11.9% of cases (Table 5 and Figures 6-9).

In any case, the initial strategy with ESWL in the treatment of ureteral stones was always equally or more effective than URSL with lower economics costs.

Regarding the safety profile, the ESWL showed higher adverse events (18.95%) than the URSL (2.35%). The adverse events in the ESWL were mainly mild and classified as a Clavien I (83.3%). The comparison of complication rate and its costs between both groups are shown in Table 6.

Discussion

There are several minimally invasive treatment options for the

Variable		ESWL	URSL	p value
		Mean (SD)	Mean (SD)	
Age		51.78 (11.79)	57.52 (14.04)	0.002*
		n/total (%)	n/total (%)	
Sex	Male	68/112 (60.71)	44/112 (39.28)	0.010*
	Female	27/68 (39.70)	41/68 (60.29)	
Stone size	<1 cm	60/109 (55.05)	49/109 (44.95)	0.450*
	≥1 cm	35/71 (49.30)	36/71 (50.70)	
Position	Lumbar ureter	68/92 (73.91)	24/92 (26.09)	0.000*
	Iliac ureter	4/25 (16.00)	21/25 (84.00)	
	Pelvic ureter	23/63 (36.51)	40/63 (63.49)	

*Student's test

^Chi square test

Table 3: Patient and Stone Characteristics. comparison between Both Groups.

Location	Size	Initial Treatment			With Rescue Treatment	
		ESWL n (%)	URSL n (%)	p value	4SWL + 2URSL n(%)	2 URSL n(%)
Lumbar	<1 cm	38 (86.36)	10 (100)	0,215*	44 (100)	-----
	≥1 cm	19 (79.17)	10 (71.42)	0,588*	23 (98,51)	13 (92,86)
Iliac	All sizes	4 (100)	20 (95.83)	0,656*	-----	20 (95,83)
Pelvic	<1 cm	10 (66.67)	28 (100)	0,001*	15 (100)	-----
	≥1 cm	6 (75)	12 (100)	0,068*	8 (100)	-----
Global		77(81)	80 (94)	0,001*		
	<1 cm	49(83)	49(98)			
	≥1 cm	28 (78)	32(91)			

Table 4: Stone free rate between groups, Comparison between initial and rescue treatment.

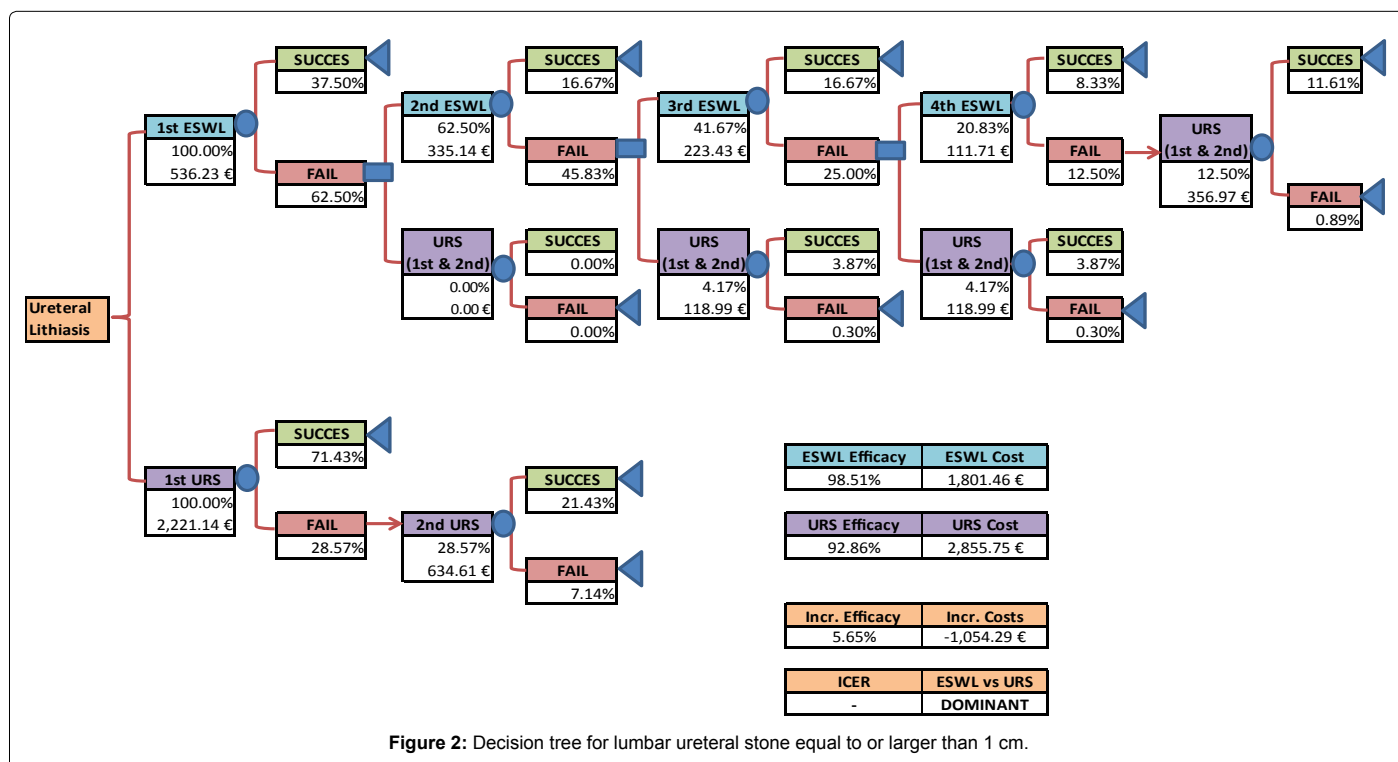
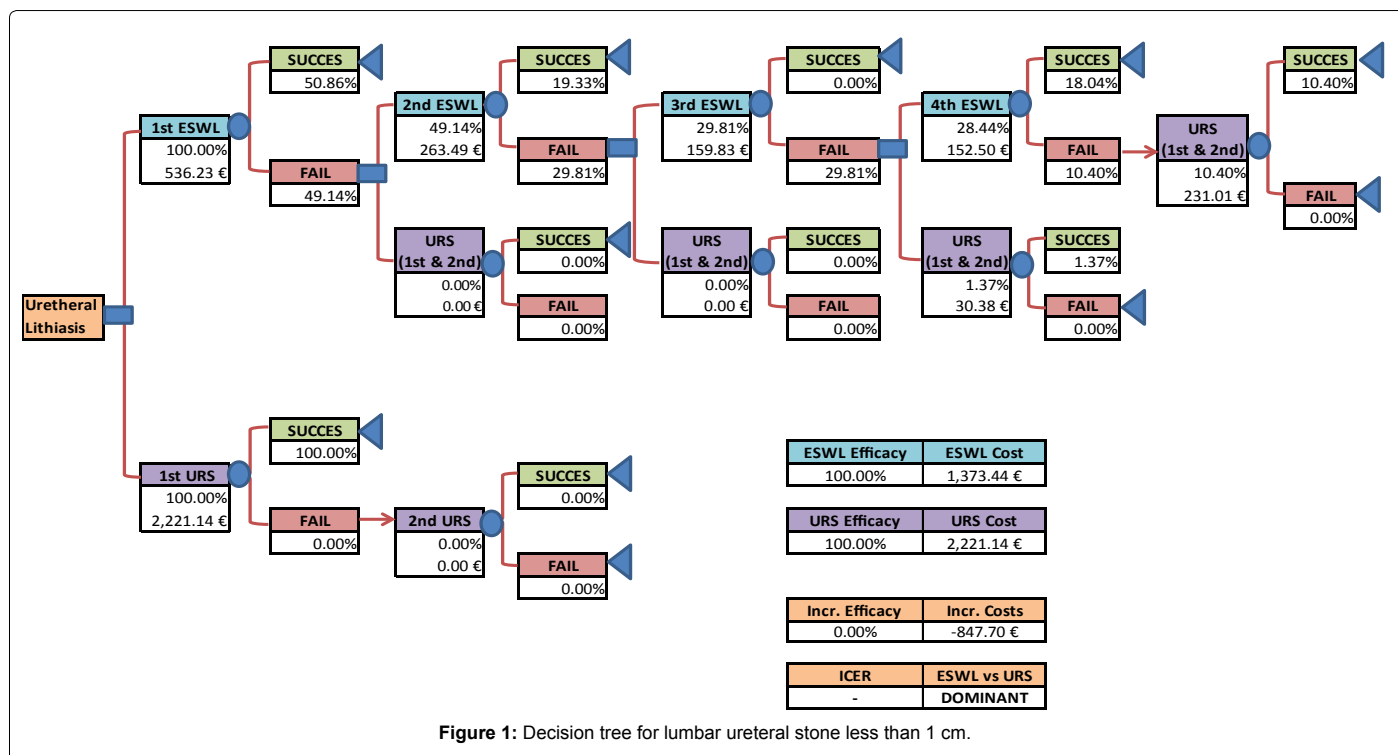

ureteral stones. The properly option depend on the stone characteristics (size, hardness and location), the available technology, surgeon's experience, success rate of each technique, predictors of failure and patient preference. Recently, there have been significant advances in the technology of both techniques. The lithotripters generate waves with higher positive peak pressure, the focal areas are smaller and better tolerated by patients. It is a safe and effective alternative, with

SFR between 50-86% for ureteral lithiasis. However, the re-treatment rate is high (11-33%) and have not improved success rates achieved by the gold standard (HM3 lithotripter). The URSL and laser technology have also improved in recent years. This advance allowed an increase success rate (79-99%), with a slightly higher complications rate (7-13%) if we compare with lithotripsy. The principal advantages of the ESWL are that it can be performed under intravenous sedation, it is a

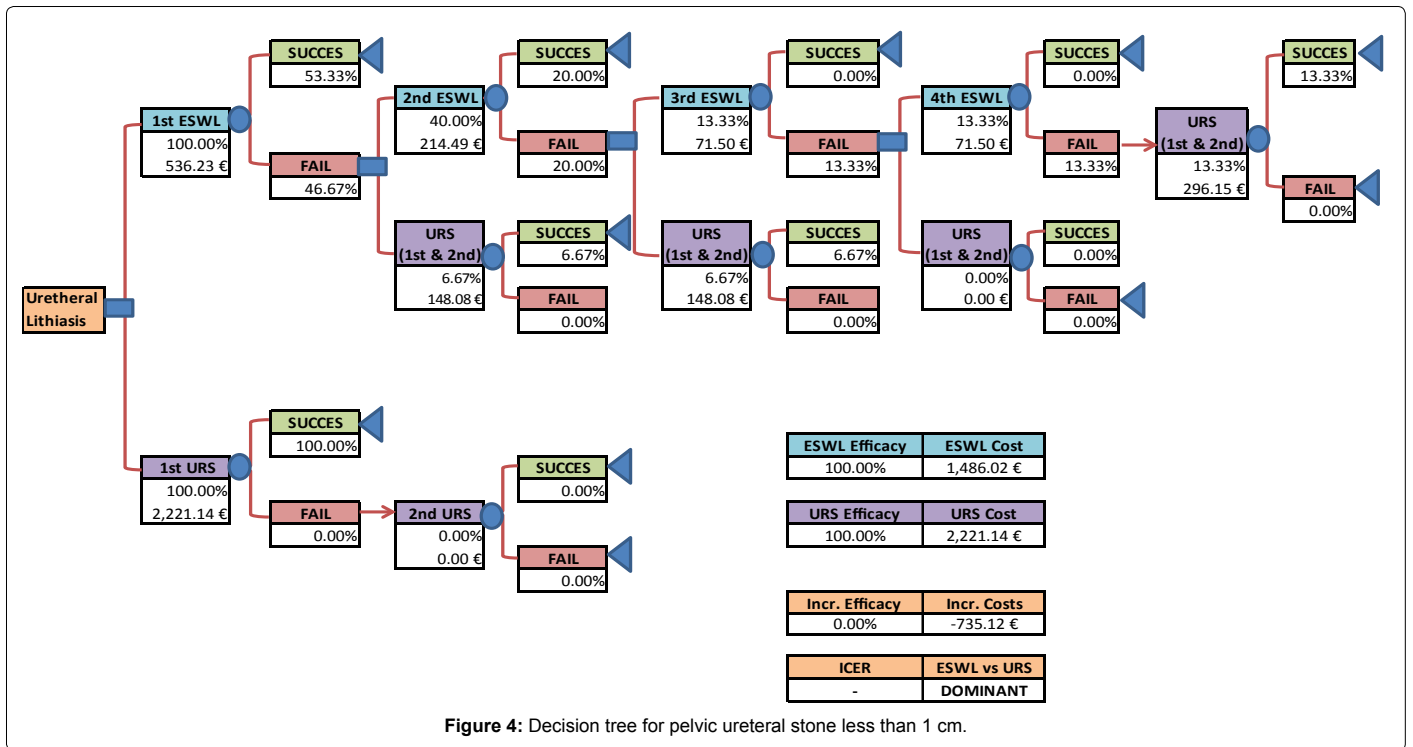
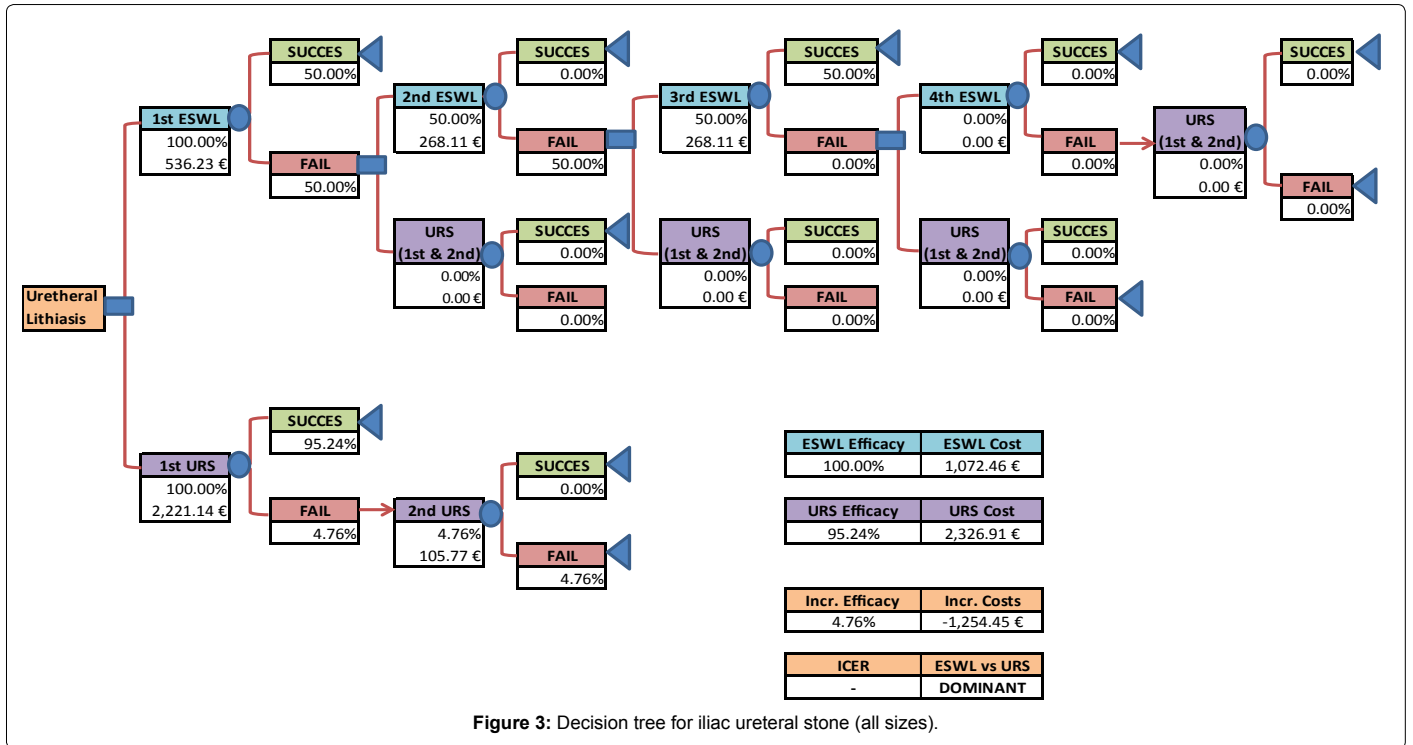

less invasive technique, with good tolerability and minimal side effects. Nevertheless, URSL requires general or spinal anesthesia, but it has shown a high success rate and a low probability of retreatments. To date, few studies have compared the optimal therapy in the management of ureteral stones. In our knowledge, this is the first study that uses a decision tree and sensitivity analysis to evaluate the efficiency of two different minimally invasive treatment strategies in ureteral lithiasis, including not only the initial treatment but also retreatments, auxiliary

maneuvers and complete follow up until resolution of the case. Thus, we evaluated the effectiveness of two strategies in the treatment of ureteral lithiasis and not just the initial treatment of choice. Despite the great heterogeneity and limited quality of available cost-effectiveness evaluations most studies demonstrated that URSL was more favorable than ESWL for ureteral stones in terms of stone-free rate and cost [11]. However, if we analyze overall available studies we can see significance differences between effectiveness and cost, depending on countries

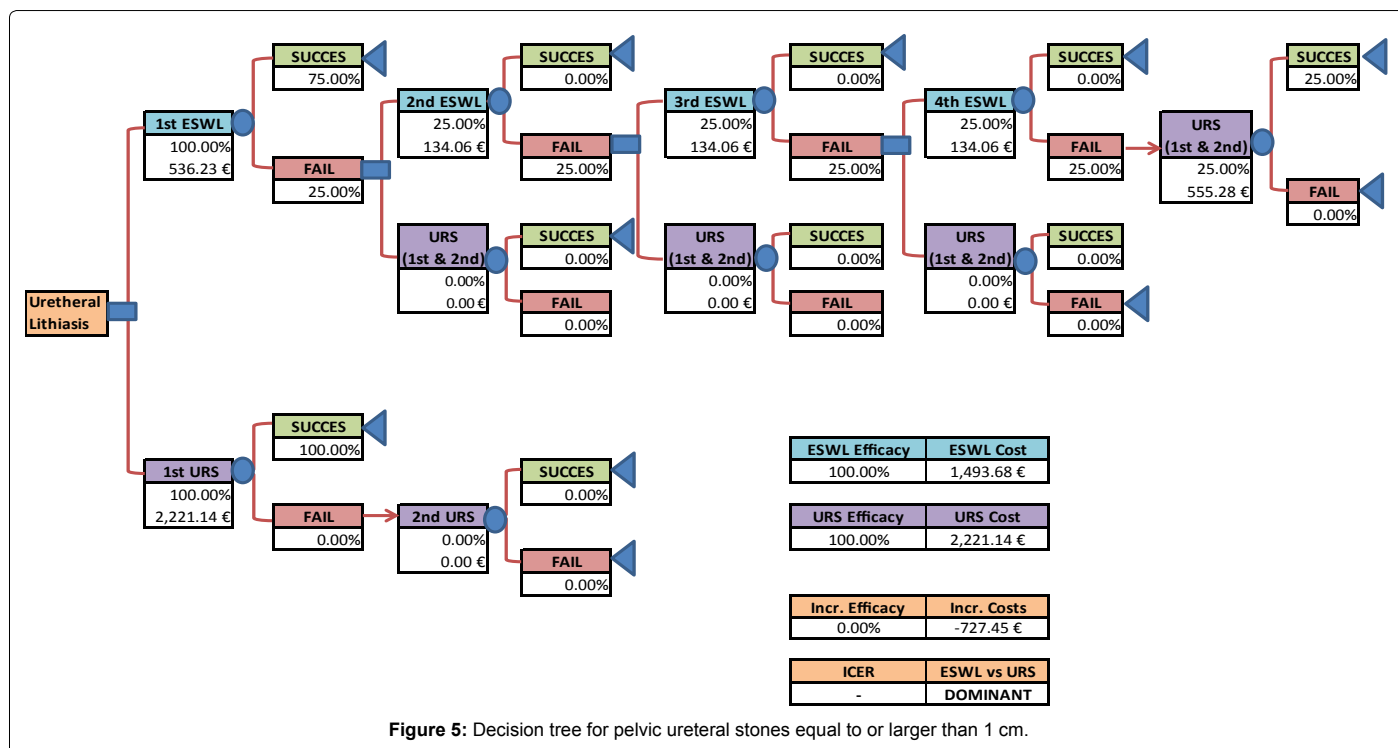

Figure 5: Decision tree for pelvic ureteral stones equal to or larger than 1 cm.

	Group A: SWL (+ URS as rescue treatment)		Group B: URS (+ second URS as rescue treatment)		Group A vs Group B
	SFR	COST	SFR	COST	
Lumbar < 1cm	100.00%	1.373.44 €	100.00%	2.221.14 €	Dominant
Lumbar ≥ 1cm	98.51%	1.801.46 €	92.86%	2.855.75 €	Dominant
Iliac. All sizes	100.00%	1.074.72 €	95.24%	2.326.91 €	Dominant
Pelvic. < 1 cm	100.00%	1.486.02 €	100.00%	2.221.14 €	Dominant
Pelvic. > 1 cm	100.00%	1.493.68 €	100.00%	2.221.14 €	Dominant

Table 5: Cost-effectiveness results.

and technologies. Furthermore, in most studies the criteria to evaluate the effectiveness of ESWL is not clear, as the author has not shown if the stone free rate is initial or after having completed the follow-up period. The studies that show initial and global SFR obtain 60% and 90% respectively [12,13]. However URSL in all studies, improve these figures achieving an initial SFR around 90%.

In evaluations performing in USA the cost for ESWL was highest and URSL was most favorable in cost effectiveness analysis [14-16]. Parker y colleagues treated 220 patients with proximal ureteral calculi using ESWL or ureteroscopy and found that URSL was more efficient with similar complications rate. The total charge for URS were \$9378 which is lower than those of ESWL with total charges of \$15583. However, the effectiveness of lithotripsy was lower compared to other studies and methodology used did not specified the direct cost from the treatment and follow up, but with the total invoice for the patient's treatment. Matlaga [17] in a systematic review, described the URSL was associated with a better SFR with and lower economic cost than URSL, thus being dominant over the ESWL. However, the authors acknowledge that it is very difficult to assess the magnitude of benefit of URSL respect to cost, given the wide variety of existing health systems. Other authors such as Chandhoke [18] obtained similar results to those described. Other studies in different health systems also showed similar results. In Egypt, Salem [19], in a prospective study of proximal ureter lithiasis, found similar results. In lithiasis larger than

1 cm (Figure 10), the SFR of URSL was significantly better than the ESWL (88% vs 60%), although stones smaller than 1 cm found no significant differences (100% vs 80%). The costs were initially higher in the URSL compare with ESWL (\$ 1026 vs \$ 1170), but when the overall costs were evaluated including additional procedures, visits and explorations, the ESWL was more expensive than the URSL (\$ 6500 vs \$ 5700). An analysis Performed in Malaysia showed also similar results [11], although either lithotripsy or ureteroscopy had low efficiency. The efficiency analysis was made with quality of life questionnaire (SF-36), and the study identified lower costs for the ureteroscopy group. However, the group that received lithotripsy had a larger median size of the stones than the ureteroscopy group, which may limit the effectiveness results, as well as it was a retrospective study design with a small sample. On the other hand, the higher cost of lithotripsy was linked it to the cost of purchasing and maintenance of the lithotripter. Cui et al. [20] found a high effectiveness with both treatments, but the cost was significantly lower for the ESWL without differences in the rate of severe complications. The recovery time was significantly lower in the ESWL group compared with the URSL group, and the lower urinary tract symptoms rates were higher for the group of the URSL. Zhang et al. [21] found no difference between the two techniques in the ureter lumbar location. In the distal location, the URSL was more effective, but the cost was favorable to lithotripsy in all locations. However, in Zhang et al. [21] study all necessary preoperative tests were performed on an inpatient basis in both forms of treatment therefore

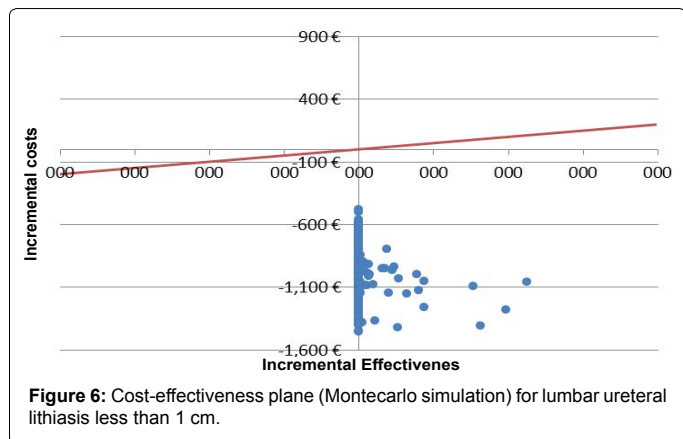

Figure 6: Cost-effectiveness plane (Montecarlo simulation) for lumbar ureteral lithiasis less than 1 cm.

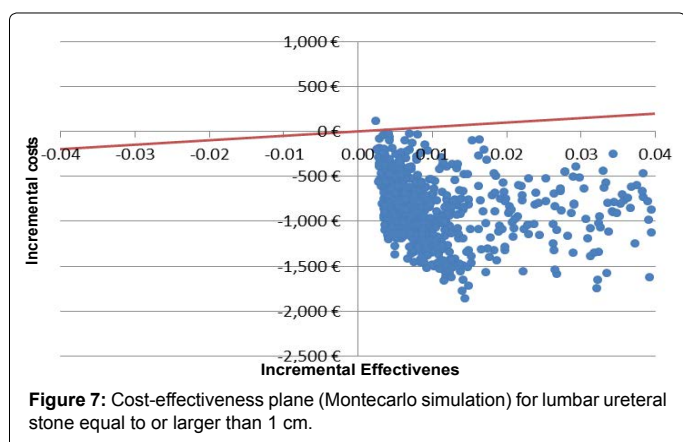

Figure 7: Cost-effectiveness plane (Montecarlo simulation) for lumbar ureteral stone equal to or larger than 1 cm.

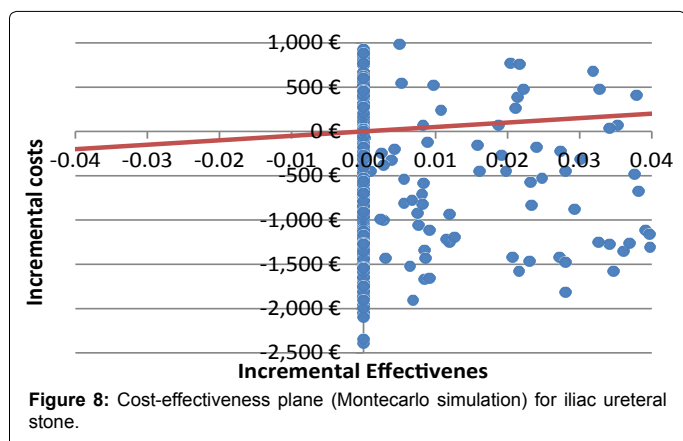

Figure 8: Cost-effectiveness plane (Montecarlo simulation) for iliac ureteral stone.

it produced an increase of the cost of stay. Moreover, the cost of the laser in the group of the URSL was billed by pulses used, which makes it difficult to compare with other studies of similar characteristics. So, ESWL costs were very low compared to European or American studies because lithotripters are self-made and their acquisition and maintenance costs are reduced significantly. Unlike other studies, we used our real terms of effectiveness, allowing us in daily practice to make informed decisions based on terms of cost-effectiveness of our own environment. Although we agree with Cone et al. [22] that clinical decisions should not be based only in terms of costs. At least we should analyze the total cost of each technique before decide one treatment option.

Our report has several points of strength. It is a prospective study

with a large number of patients, with an exact definition of the size, location, SFR, time in which it is determined the SFR, complications and retreatments as well as rescue treatments performed. The methodology uses as a therapeutic decision tree or a sensitivity analysis provide strength in our results.

However, the main limitations of our study were the small number of patients with iliac stones, which did not allow us to stratify according to size. The treatment election was performed by patient decision after receiving complete information about the different procedures, making

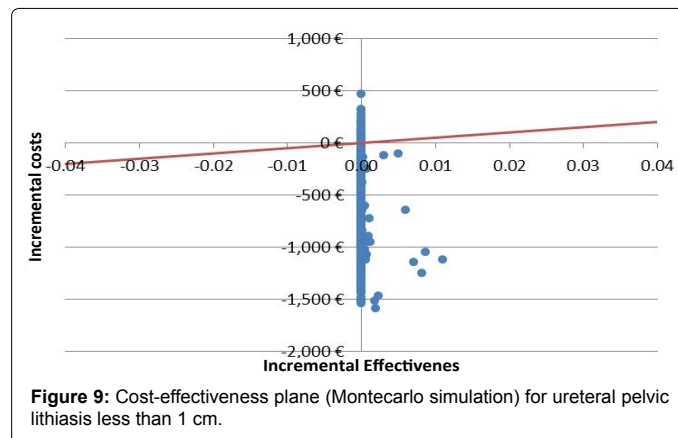
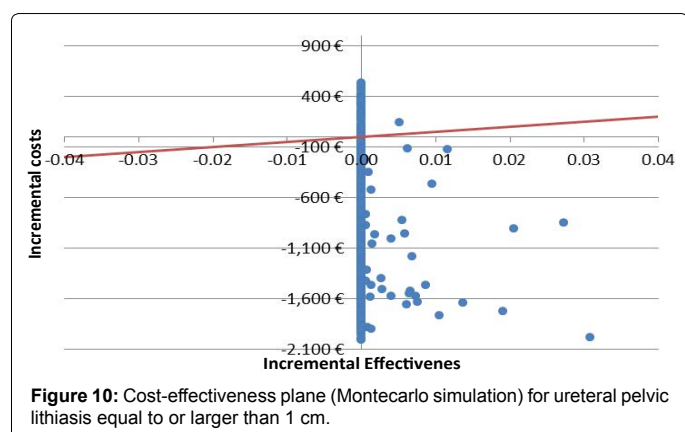

Figure 9: Cost-effectiveness plane (Montecarlo simulation) for ureteral pelvic lithiasis less than 1 cm.

All Sizes and positions				
Complications	Clavien	Costs (€)	ESWL n(%)	URSL n(%)
Without complications			77 (81.05)	83 (97.65)
Renal colic	1	162.11	13 (13.68)	0(0)
Urinary infection	2	162.11	4 (4.21)	1 (1.18)
Hematoma	2	2.228.81	0 (0.00)	1 (1.18)
Sepsis	4	3.902.92	1 (1.05)	0 (0)
Lumbar Lithiasis				
Stones < 1 cm				
Complications	Clavien	Costs €	ESWL	URSL
Without Complications			35 (79.55)	10 (100)
Renal Colic	1	162.11	6 (13.64)	0(0)
Urinary Infection	2	162.11	2 (4.55)	0 (0)
Sepsis	4	3.902.92	1 (2.27)	0 (0)
Stones ≥ 1 cm				
Complications	Clavien	Costs €	ESWL	URSL
Without Complications			21 (87.50)	13 (92.86)
Renal Colic	1	162.11	3 (12.5)	
Hematoma	2	2.228.81	0 (0)	1 (7.14)
Iliac Lithiasis (all sizes)				
Complications	Clavien	Costs €	ESWL	URSL
Without Complications			2 (75.00)	21(100)
Renal Colic	1	162.11	1 (25.00)	0(0)
Urinary Infection	2	162.11	1 (25.00)	0 (0)
Pelvic Lithiasis				
Stones < 1 cm				
Complications	Clavien	Costs €	ESWL	URSL
Without Complications			14 (93,33)	28 (100)
Renal Colic	1	162.11	1 (6,67)	0 (0)
Stones ≥ 1 cm				
Without Complications			5 (62,5)	11 (91,67)
Renal Colic	1	162.11	2 (25,00)	0 (0)
Urinary Infection	2	162.11	1 (12,5)	1 (8,33)

Table 6: Analysis of adverse events.



it impossible randomization in both study groups. Likewise, indirect costs (patient and family) associated with the period of convalescence of each therapeutic modality were not considered. In addition, we did not take into account the quality of life and patient satisfaction. This analysis should provide a fuller comparison of both techniques.

Conclusions

The results of our study show that the ESWL as an initial treatment strategy is more efficient in terms of cost-effectiveness than URSL as initial treatment in the treatment of ureteral stones, regardless of the size of the calculi, in our country. In our opinion, urologists should evaluate the economic impact of treatment stone with the goal of maximizing clinical and economic outcomes besides patient satisfaction.

References

- Lam JS, Greene TD, Gupta M (2002) Treatment of proximal ureteral calculi: holmium: YAG laser ureterolithotripsy versus extracorporeal shock wave lithotripsy. *J Urol* 167: 1972-1976.
- Wu CF, Shee JJ, Lin WI, Lin CL, Chen CS (2004) Comparison between extracorporeal shock wave lithotripsy and semirigid ureterorenoscope with holmium:YAG laser lithotripsy for treating large proximal ureteral stones. *J Urol* 172: 1899-1902.
- Hutubessy RC, Baltussen RM, Torres-Edejer TT, Evans DB (2002) Generalised cost-effectiveness analysis: an aid to decision making in health. *Appl health econand health policy* 1: 89-95.
- Siegel JE, Weinstein MC, Russell LB, Gold MR (1996) Recommendations for Reporting Cost-effectiveness Analyses *JAMA* 276: 1339-1341.
- Baltussen R, Hutubessy RCW, Evans DB, Murray CJ (2002) Uncertainty in cost-effectiveness analysis. Probabilistic uncertainty analysis and Stochastic league tables. *International J of Technol Assess in Health Care* 18: 112-119.
- Briggs A, Sculpher M, Claxton K (2006) Key aspects of decision modelling for economic evaluation. In *Decision Modelling for Health Economic Evaluation*. Oxford University Press. Oxford.
- Haddix AC, Teutsch SM, Phaedra S (2003) *Decision Analysis. Prevention Effectiveness: A Guide to Decision Analysis and Economic Evaluation*. Oxford University Press. Oxford.
- Critchfield GC, Willard KE, Connelly DP (1986) Probabilistic sensitivity analysis methods for general decision models. *Comput Biomed Res* 19: 254-65.
- Weinstein MC, O'Brien B, Hornberger J, Jackson J, Johannesson M, et al. (2003) Principles of good practice for decision analytic modeling in health-care evaluation: report of the ISPOR Task Force on Good Research Practices--Modeling Studies. *Value Health* 6: 9-17.
- Cleemput I, Neyt M, Thiry N, De Laet C, Leys M (2011) Using threshold values for cost per quality-adjusted life-year gained in healthcare decisions. *Int J Technol Assess Health Care* 27: 71-76.
- Izamin I, Aniza I, Rizal AM, Aljunid SM (2009) Comparing extracorporeal shock wave lithotripsy and ureteroscopy for treatment of proximal ureteric calculi: a cost-effectiveness study. *Med J Malaysia* 64: 12-21.
- Wu CF, Chen CS, Shee JJ, Lin WY (2005) Therapeutic options for proximal ureter stone: extracorporeal shock wave lithotripsy versus semirigid ureterorenoscope with holmium:yttrium-aluminum-garnet laser lithotripsy. *Urology* 65: 1075-1079.
- Lotan Y, Pearle MS (2007) Economics of stone management. *Urol Clin North Am* 34: 443-453.
- Wolf JS Jr, Carroll PR, Stoller ML (1995) Cost-effectiveness v patient preference in the choice of treatment for distal ureteral calculi: a literature-based decision analysis. *J Endourol* 9: 243-248.
- Parker BD, Frederick RW, Reilly TP, Lowry PS, Bird ET (2004) Efficiency and cost of treating proximal ureteral stones: shock wave lithotripsy versus ureteroscopy plus holmium:yttrium-aluminum-garnet laser. *Urology* 64: 1102-1106.
- Lotan Y, Gettman MT, Roehrborn CG, Cadeddu JA, Pearle MS (2002) Management of ureteral calculi: a cost comparison and decision making analysis. *J Urol* 167: 1621-1629.
- Matlaga B, Jansen J, Meckley L (2012) Economic outcomes of treatment for ureteral an renal stones: A systematic Literature review. *J Urol* 188 449-454.
- Chandhoke PS (2001) Economics of urolithiasis: cost-effectiveness of therapies. *Curr Opin Urol* 11: 391-3.
- Salem HK (2009) A Prospective Randomized Study Comparing Shock Wave Lithotripsy and Semirigid Ureteroscopy for the Management of Proximal Ureteral Calculi. *Urology* 74: 1216-1221.
- Cui H, Thomee E, Noble JG, Reynard JM, Turney BW (2013) Efficacy of the lithotripsy in treating lower pole renal stones. *Urolithiasis* 41: 231-234.
- Zhang J, Shi Q, Wang GZ, Wang F, Jiang N (2011) Cost-effectiveness analysis of ureteroscopic laser lithotripsy and shock wave lithotripsy in the management of ureteral calculi in eastern China. *Urol Int* 86: 470-475.
- Cone EB, Eisner BH, Ursiny M, Pareek G (2014) Cost-effectiveness comparison of renal calculi treated with ureteroscopic laser lithotripsy versus shockwave lithotripsy. *J Endourol* 28: 639-643.