

Acquire Bus Information using GSM Technology

K Shirisha^{1*} and T Sivaprasad²

¹Assistant professor, Department of Electronics and Communication Engineering, Aurora's technological and research institute, Hyderabad, India

²Assistant professor, AAR Mahaveer Engineering College, Hyderabad, India

*Corresponding author: Shirisha K, Assistant professor, Department of Electronics and Communication Engineering, Aurora's technological & research institute, Hyderabad, India; Tel: +91 8519834665; E-mail: kadalisirisha4@gmail.com

Received date: May 25, 2016; Accepted date: June 28, 2016; Published date: June 25, 2016

Copyright: © 2016 Shirisha K. This is an open-access article distributed under the terms of the Creative Commons Attribution License, which permits unrestricted use, distribution, and reproduction in any medium, provided the original author and source are credited.

Abstract

The system designed here is very useful for the passengers those who are waiting at bus stop to catch specific number bus. As the bus is equipped with GSM based processor and where as the bus stop is equipped with time data transmitter, the passenger can identify that at what time the bus has reached to its previous stage or before that stage. Based on this information, the passenger can estimate the position of bus. This can be achieved by sending SMS to the GSM installed in the bus.

The demo module is simulated with two bus stages and each stage has to be equipped with its time data transmitting unit. This unit contains RTC and it is interfaced with microcontroller can display the running time accurately through 7- segment display. This time data is transmitted continuously through IR led. Now whenever the bus reaches to the stage, this time data will be acquired through TSOP (IR sensor package) and it will be stored in to the ROM of main processing unit. The GSM module interfaced with main processor can send the time information along with left over bus stop name (i.e. reaching time of previous bus stop) to the caller in the form of SMS. Means whenever any passenger enquires to know the position of bus by sending SMS to the concern processor installed in the bus, information will be passed to the calling mobile automatically. Since it is a prototype module, system is developed for two stages, but for practical approach each and every bus stop must be equipped with real time clocks with data transmitters and similarly each and every bus also must be equipped with the processing unit. In this fashion all buses information can be acquired by calling them through mobile.

Major building blocks: RTC's, Micro-controllers, 7- segment displays, modulators, TSOP1738 IR sensor package, Max232, GSM module. Simulation of bus stops, toy bus, high power battery and its charger, etc.

Keywords: GSM; Microcontrollers; Transmitter; Receiver

Introduction

In this urban life transportation is very common. A large number of people rely on the bus services provided to them by private/ government organizations. Most of the times, the general public are left clueless whether a particular bus is still available or not. Therefore the need of continuous monitoring is to be developed. To resolve such problems, a system is developed using GSM technologies and an application is introduced in this research work.

Various problems that we face

- In urgent situations one is confused whether to rely on public transport of the bus or simply spend money on a cab.
- To find the nearest bus.

All these problems are overcome by the system. This system has Real time clock and a GSM controller which will receive the time and stage data from the sensors among other critical information. The tracking system is very important in modern world. This can be useful in soldier monitoring, tracking of the military vehicles and various other applications. The system is microcontroller based that consists of global system for mobile communication (GSM). This project uses only one GSM device and a two way communication process is

achieved using a GSM modem. The GSM modem, provided with a SIM card uses the same communication process as we are using in regular phone.

The system is not limited to find the location of the target but also stores the time at both the stations.

This system is user friendly, easily installable, easily accessible and can be used for various other purposes. After installation, the system will be able to locate the target by the use of GSM technology and time information.

Literature Survey

Real-time tracking and management of vehicles has been a field of interest for many researchers and a lot of research work has been done for tracking system. Recently the various anti-theft modules like steering wheel locked equipment, network tracking system and traditional electronic alarm are developed along with client identification and real time performance monitoring.

The paper presented by El-Medany et al. describes a real time tracking system that provides accurate localizations of the tracked vehicle with low cost [1]. GM862 cellular quad band module is used for implementation. A monitoring server and a graphical user interface on a website is also developed using Microsoft SQL Server 2003 and ASP.net to view the proper location of a vehicle on a specific map. The

paper also provides information regarding the vehicle status such as speed, mileage.

Jian-ming et al. describe an automobile anti-theft system using GSM and GPS module. The system is developed using high speed mixed type single-chip C8051F120 and stolen automobile is detected by the use of vibration sensor. The system remains in contact with automobile owner through the GSM module, for the safety and reliability of automobile [2]. Nagaraja describes development and deployment of GPS (Global Positioning System)/GSM (Global System for Mobile Communications) based Vehicle Tracking and Alert System [3]. This system allows inter-city transport companies to track their vehicles in real-time and provides security from armed robbery and accident occurrences [4].

El-Medany et al. describes a system based on the Global Positioning System (GPS) and Global System for Mobile Communication (GSM) [5]. It describes the practical model for routing and tracking with mobile vehicle in a large area outdoor environment. The system includes the Compass sensor-YAS529 of Yamaha Company and Accelerator sensor-KXSC72050 of Koinix Company to acquire moving direction of a vehicle. The system will acquire positions of the vehicle via GPS receiver and then sends the data to supervised center by the SMS (Short Message Services) or GPRS (General Package Radio Service) service. The supervised center comprises of a development kit that supports GSM techniques-WMP100 of the Wavecom Company. Finally, the position of the mobile vehicle will be displayed on Google Map.

System Architecture

The system consists of two units. One is transmitting side (station side) and other one is receiver side (module present in the bus).

Description of receiving unit

GSM: GSM modem is used for transmitting and receiving the data. SIM 300 is a tri- band GSM/GPRS engine. It works on various frequencies i.e. EGSM 900MHz, DCS 1800MHz and PCS 1900MHz.

Microcontrollers: The system uses two CMOS 8-bit microcontroller, the 8051 and the 8052. They are based on Harvard architecture and they comprise of 128/256 bytes of program memory, 4/8 Kilo bytes of internal ROM, and 2/3 timers/counters based on 8051 and 8052 respectively. The 8052 is used as the capturing module in order to capture the stage data from the TSOP IR sensor and the time data from the RTC module. The 8051 microcontroller on the other hand is used in the calling module in order to work with the GSM module for transmitting and receiving messages between the GSM module and the capturing module.

MAX 232: It is used for the GSM and microcontroller to communicate serially as it acts as an interface between the two devices.

16x2 LCD: A 16x2 LCD is used for displaying time data for the respective stages. A 9v battery is used to power up the circuit.

Monitoring unit: The monitoring unit is nothing but a TSOP 1738 IR sensor package which is able to detect a frequency of 38 KHz. This unit is responsible for capturing the stage data and transmitting the same to the micro controller unit which is the capturing module.

RTC module: The RTC (Real time clock) module consists of a DS 1307 IC which is time keeper IC. This module is responsible for running the time perennially and hence a dedicated cell is provided to

this module for the same reason. The time data is transmitted serially to the capturing module on detection of a stage.

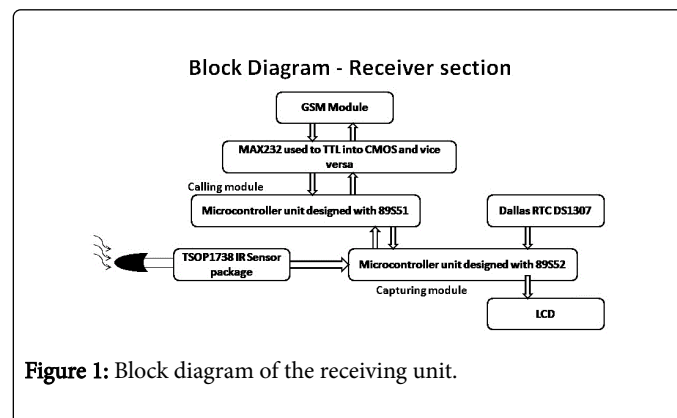

Figure 1: Block diagram of the receiving unit.

Description of transmitting unit

555 timer in astable mode: For the purpose of a carrier signal in the transmitting end, we use a 555 timer that operates in the astable mode. The frequency of the carrier generated is adjusted to 38 KHz for synchronous reception purposes.

Microcontroller: A 2051 Microcontroller is used in order to transmit the message signal which helps identify which stage is being detected. The two stages in the module have a unique code. The 2051 and 555 timer IC work together and produce a modulated signal which is further detected by the receiver at the receiving end.

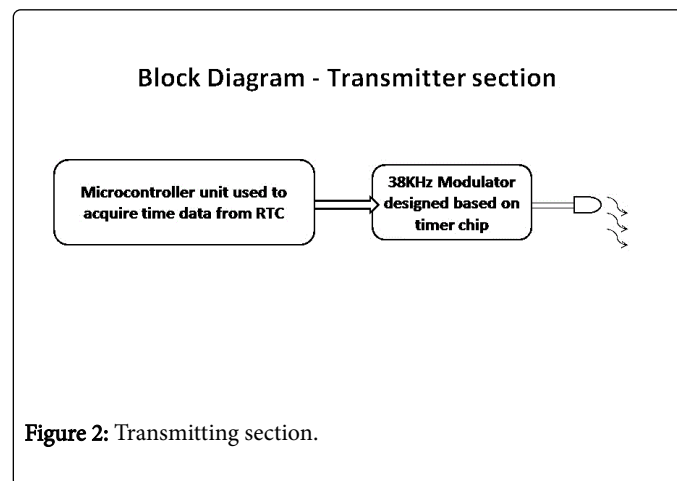

Figure 2: Transmitting section.

Programming Logic

- The transmitter continuously transmits the stage data.
- When a bus reaches a particular stage, its data is captured with immediate effect by the TSOP IR sensor package present inside the bus.
- As soon as the stage data is captured and obtained by the capturing module, the capturing module obtains the time data at that exact same time from the RTC module.
- Simultaneously when a user generates a request, the calling module acquires the information collected by the capturing module and hands it over to the GSM module for transmission.

- Thus a user of the service gets back a status message and is able to track the stage of the bus or the transport service.

Hardware Design

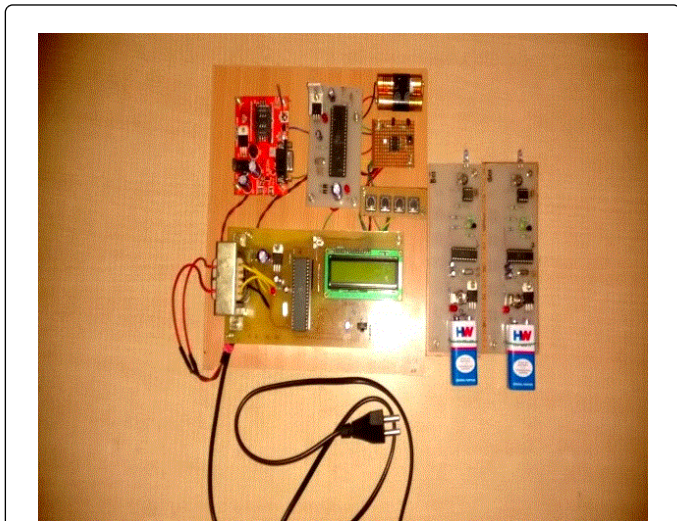

Figure 3: Overall module.

- Industrial applications which also involve transport of raw as well as finished products can be tracked with respect to check-points present within the factory or the industry.

Advantages

- The module is cost effective as most of the electronic equipment are available in the market at cheap rates
- The project is also fully automated and it doesn't require unnecessary manual interruption in between as everything is taken care of by the modules fully well.
- It is very reliable as it used satellite communication and seldom does it fail to deliver.

Disadvantages

- There are chances that the network coverage might be low at some places causing the service to not function properly.
- The circuitry used is a little complicated and can be improvised upon.
- Power consumption is high.

Conclusion

A one stops solution for rendering highly precise information for everyday travelers in an urban or semi-urban environment.

References:

1. El-Medany W, Al-Omary A, Al-Hakim R, Al-Irhayim S, Nusaif M (2010) A cost effective real-time tracking system prototype using integrated GPS/GPRS module, 6th International conference on wireless and mobile communications (ICWMC), Valencia.
2. Jian-ming H, Jie L, Guang-Hui L (2012) Automobile anti-theft system based on GSM and GPS module, Fifth International conference on intelligent networks and intelligent systems (ICINIS), Tianjin.
3. Nagaraja BG, Rayappa R, Mahesh M, Patil CM, Manjunath TC (2009) Design & development of a GSM based vehicle theft control system, International conference on advanced computer control (ICACC '09), Singapore.
4. Parvez MZ, Ahmed KZ, Mahfuz QR, Rahman MS (2010) A theoretical model of GSM network based vehicle tracking system, International conference on electrical and computer engineering (ICECE), Dhaka.
5. El-Medany WM, Alomary A, Al-Hakim R, Al-Irhayim S, Nousif M (2010) Implementation of GPRS- Based Positioning System Using PIC Microcontroller, Second International Conference on Computational Intelligence, Communication Systems and Networks (CICSyN), Liverpool.

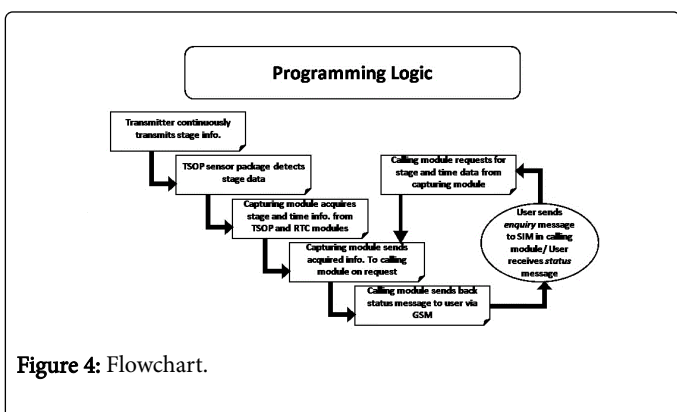

Figure 4: Flowchart.

Applications

- Services can be extensively availed by public transport users.
- This can also be used for military operations where military equipment can be tracked while being transported between friendly bases.