

A Soft Computing Model for Evaluating Teachers' Overall Performance using Fuzzy Logic

Javed Alam* and Manoj Kumar Pandey

Computer Science & Applications AIMCA, Amrapali Group of Institutes, Haldwani, Nainital, Uttarakhand, India

*Corresponding author: Javed Alam, Computer Science & Applications AIMCA, Amrapali Group of Institutes, Haldwani, Nainital, Uttarakhand, India, Tel: 91-9557592020; E-mail: javedalam4u@gmail.com

Received date: March 06, 2017; Accepted date: March 30, 2017; Published date: April 05, 2017

Copyright: © 2017 Alam J, et al. This is an open-access article distributed under the terms of the Creative Commons Attribution License, which permits unrestricted use, distribution and reproduction in any medium, provided the original author and source are credited.

Abstract

In the entire world, there is a widespread recognition that evaluation framework is a key to building stronger and fairer academic institution system. All countries emphasize the evaluation not as end in itself but instead an important tool for achieving improved student outcomes. Teacher evaluation typically has two major purposes. First, it seeks to improve the teacher's own practice by identifying strengths and weaknesses for further professional development and involves helping teachers learn about, reflect on and adjust their practice. Second it is aimed at holding teacher's accountability for their performance in enhancing student learning. It typically entails performance based career advancement and/or salaries, bonus pay, or the possibility of sanctions for underperformance and usually involves evaluating performance at nodal points in a teacher's career. The term soft computing represents the combination of emerging problem solving technologies, such as fuzzy logic, probabilistic reasoning, neural networks and genetic algorithms. Each of these technologies provides us with complementary reasoning and searching methods to solve complex real world problems. We have proposed a soft computing model for evaluating teachers' overall performance using fuzzy logic. There are two different modules namely teachers' overall performance module-1 (TOP-M1) and teachers' overall performance module-2 (TOP-M2). First module TOP-M1, calculates teaching performance. Second module TOP-M2, calculates academic and administrative performance. On the bases of teaching performance and academic and administrative performance we calculate overall performance. Software has been developed in MATLAB. This soft computing model for evaluating teachers' overall performance using fuzzy logic will not only be useful for decision makers to evaluate teachers' abilities and improve student outcomes but may also be adopted in writing Annual Confidential Reports(ACR) for appraisal of all the teachers of an academic institution. Simulation results verify the performance of our proposed soft computing model for evaluating teachers' overall performance using fuzzy logic.

Keywords: Overall performance; Soft computing; Fuzzy logic; TLA; SRUE; TP; AAP

Introduction

Soft computing is a recently coined term describing the symbiotic use of many emerging computing disciplines. According to Zadeh, "in contrast to traditional, hard computing, soft computing is tolerant of imprecision, uncertainty, and partial truth". In the context of our discussion we will consider fuzzy logic as soft computing main components. Fuzzy logic introduced by Zadeh, gives us a language with syntax and local semantics in which we can translate our qualitative knowledge about the problem to be solved. Fuzzy logic's main characteristic is the robustness of its interpolative reasoning mechanism [1].

We try to solve the problems of the real world as it is, but we feel that they are usually ill-defined and difficult to model large-scale system solutions spaces. For these cases almost all existing models are too expensive and impractical.

Therefore, we need approximate reasoning system, that capable of handling such types of imperfect information system. Soft computing technologies provide us with a set of flexible computing tools to perform these search tasks and approximate reasoning. In the context of the current interest in measuring teacher's effectiveness, teacher quality and teaching quality is important to distinguish between them.

Teacher quality might be thought of as the bundle of skills, personal traits, and understandings an individual brings to teaching including dispositions to behave in certain ways. Teacher effectiveness, teacher evaluation and student achievement based on the benefits of research, the following properties have been found to be important.

Strong content knowledge related to what is to be taught. Knowledge of how to teach others in that area and skill in implementing productive instructional and assessment practices.

Understanding of learners and their development, including how to support students who have learning differences or difficulties, and how to support the learning of language and content for those who are not already proficient in the language of instruction.

General abilities to organize and explain ideas as well as to observe and think diagnostically. Adaptive expertise that allows teachers to make judgments about what is likely to work in a given context in response to students' needs.

Most policymakers, educators and parents would also include important dispositions in this list such as, teach in a fair and unbiased manner, the willingness to support learning for all students adapt instruction to help students succeed, strive to continue to learn and improve and collaborate with other professionals and parents in the service of individual students and the institution as a whole. These features are based on teaching supported by research. In development

of standards and assessment for teacher we need to define knowledge base teaching, includes research on development, learning, curriculum etc.

Related Works

In this section, we discuss different research work in the field of evaluating teachers' overall performance using fuzzy logic. Khan et al. [2] discuss a paper entitled "Application of Expert System with Fuzzy Logic in Teachers' Performance.

Evaluation in this research expert system was adopted using fuzzy logic [3] principals for teachers' evaluation process. In this research they have developed the knowledge acquisition tool for the teachers' assessment problem in the development of intelligent expert system. They have extracted a set of 99 attributes from literature that have influence on teachers' performance by any means in higher education the extracted attributes were divided in to 15 groups.

Pavani et al. [4] in "Evaluation of teacher's performance using fuzzy logic techniques" proposed to take help of students' feedback to apply fuzzy logic in performance evaluation of teacher. There are five fuzzy inputs i.e., Knowledge, Speed of delivery, Presentation, Overall impression, Explanation and one output i.e., Performance. In this research developed FIS with different input parameters to evaluate the performance of teacher using two different membership functions triangular, trapezoidal and compared the performance.

Bhosale et al. [5] developed a fuzzy inference system for teaching staff performance appraisal using MATLAB. The model can be viewed as an alternative to the use of addition in aggregating the scores from all categories and to produce a final score. The factors used for evaluating the performance are considered as input parameters for fuzzification. The study utilizes fuzzy inference system to deal with the problem associated with rule explosion. The proposed fuzzy inference system is implemented using Mamdani-type inference. To defuzzification the resulting fuzzy set the center of gravity method is selected. This research can be extended by considering remaining categories for the evaluation of teacher's performance and can be used for judgmental and developmental purposes in order to make good administrative decisions in higher education field.

Jyothi et al. [6] proposed an optimized interactive online faculty performance appraisal system that provides faculties meaningful appraisals to encourage professional learning and growth. The process is designed to foster teacher development and identify opportunities for additional support where required. To assess the performance of individual faculty in the institutions by integrating planning and review in the areas viz., Feedback from students, Teachers self-appraisal, Assessment by peers, and Results of University exams by providing a structured Online Interactive Interface that possesses potential related assessment data of Faculty in educational institutions. By helping teachers achieve their full potential, the performance appraisal process represents one element of achieving high levels of student performance [7].

Kamath [8] proposed a model that can be adopted for the evaluation of teacher's performance in order to make good administrative decisions. Application of the fuzzy set theory in evaluation systems can improve evaluation results. For performance assessment and adequate support in decision making this model produced significant bases. This model based on Teaching, Learning and Evaluation, Co-curricular, Extension, Professional Development,

Research, Publications and Academic Contributions related activities. There are three fuzzy inputs and one output. In this model center of gravity method is used for defuzzification.

Although many evaluation methods for selecting or ranking have been suggested in the literature, as yet there is no method which can give a satisfactory solution to every situation.

Higher education institutions and especially the government increasingly want to be assured of the quality of teaching. To achieve this objective, universities/educational institutions have to provide authentic and concrete system to evaluate the performance of teacher. In practice, evaluation of the quality of teaching depends on many factors and criteria. To evaluate the quality of teaching, the universities need to define various measures and their attributes necessary for good teaching. This paper discuss soft computing model using fuzzy set theory to analyze the quality of teaching methods by combination of quantitative discussion.

Classical theories, statements used in yes or no, either true or false, but we cannot define both, such as teaching quality can be good or not good. In contrast, fuzzy set theory approach, a statement can have values in the range (0, 1), thus teaching quality can be expressed as worst, bad, medium, good, excellent and so on. This subjective approach and assessment criteria measuring the fuzzy sense to improve the environment and will give you more options. Fuzzy environmental ambiguity, opacity and /or information on the problem at hand, the lack of a specific element is associated with a position. Fuzzy set theory to define the subjective attributes can be applied. Moreover, the application of fuzzy set theory as an effective way to formulate a decision problem where available inputs are subjective and imprecise.

Description of the Proposed Evaluating Teachers' Overall

Performance

One of the drawbacks of the conventional faculty evaluation methods is the lack of information behind the evaluation methods that have been used and set of criteria for the 'final result'. To do so, a fuzzy approach has been used to perform the proposed method of teachers' overall performance evaluation. It is important to point out that the aim of the proposed method is not to replace the current conventional method of evaluation, instead of, it will strengthen the present system by providing more information to be used for decision making by the user through automatic system.

The evaluation of teaching activity can be defined as the systematic evaluation of teaching performance according to the professional role and contribution required to reach the objectives of the course in question taking into consideration the institutional context. Therefore, teaching activity implies the planning and management of teaching, the deployment of teaching methods, learning and evaluation activities, and finally the revision and improvement of the procedures carried out. A multicriteria analysis in ranking the quality of teaching using fuzzy rule is proposed by Mahmod Othman [9]. To put the existing teachers on track, it is very necessary to evaluate their performance, may be quarterly, in semester or annually depends upon the resources in academic institutes possess. University or the institutions of higher education do not have uniform standard method or computerized solution for evaluating teachers' performance that covers all factors affecting directly or indirectly the quality of university

or the institutes. Hence a soft computing model for evaluating teachers' overall performance through his or her involvement in the various sub activities in the institute using fuzzy logic is required.

Fuzzy logic theory was introduced by Professor Lotfali Asker Zadeh University of California Berkley in 1965. The fuzzy logic controller is considered as a good methodology because it yields results superior to those obtained by conventional control algorithms. Fuzzy logic provides an alternative way to represent linguistic and subjective attributes of the real world in computing. A basic architecture of fuzzy logic controller is shown in Figure 1.

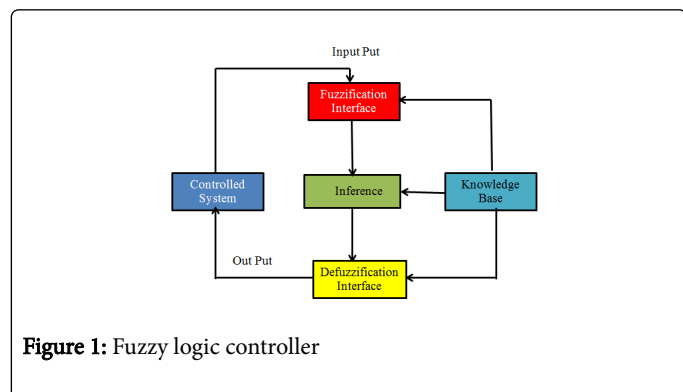

Figure 1: Fuzzy logic controller

In soft computing model for evaluating teachers' overall performance fuzzy logic [10] reasoning approach has been used for designing of Fuzzy inference system (FIS) for the controllers. There are two different modules namely teachers' overall performance module-1 (TOP-M1) and teachers' overall performance module-2 (TOP-M2). The whole structure of TOP-M1 and TOP-M2 is shown respectively. In first module TOP-M1, calculates teaching performance. In second module TOP-M2, calculates academic and administrative performance. On the bases of teaching performance and academic and administrative performance we calculate overall performance.

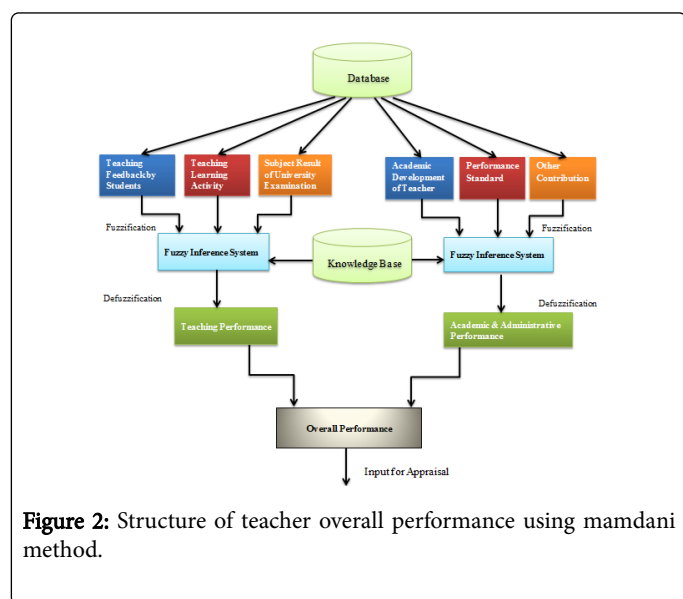

Figure 2: Structure of teacher overall performance using mamdani method.

As shown in Figure 2, fuzzy inputs teaching feedback by students (TFS), teaching learning activity (TLA) and subject result of university examination (SRUE) were combined to give teaching performance (TP). Similarly fuzzy inputs academic development of teacher (ADT),

performance standard (PS) and other contribution (OC) were combined to give academic and administrative performance (AAP). Teaching performance and academic and administrative Performance were combined to give overall performance.

Fuzzy Parameters and their Membership Functions Design

In soft computing model for evaluating teachers' overall performance using fuzzy logic, we develop six different inputs variables namely teaching feedback by students (TFS), teaching learning activity (TLA), subject result of university examination (SRUE), academic development of teacher (ADT), performance standard (PS) and other contribution (OC). There are two different output variables teaching performance (TP) and academic and administrative performance (AAP). Each of the inputs variables and outputs variables value of params, linguistic and range is shown in Table 1.

Rating Scale (RS) : Outstanding - 4, Good-3, Fair-2, Poor-1		RS
Class	Faculty Name	
A	PREPARATION	
1	The teacher had a clearly designed lesson and lecture plan.	
2	There was an appropriate balance of structured and open-ended/communicative activities/examples.	
3	Was the teacher prepared?	
4	Was the time used effectively?	
5	The teacher stated the learning outcome during lecture.	
B	CONTENT PRESETATION	
6	The lecture was geared towards proper course content coverage.	
7	The lecture was presented effectively and clearly.	
8	The activities/exercises chosen to achieve the objectives were effective.	
9	The teacher helped students get interested in the topics.	
10	The teacher welcomed questions/comments.	
11	The amount of teacher talk and student talk was appropriate.	
12	The teacher answered /responded to questions and comments clearly and concisely.	
13	The type and amount of assessment was effective and feedback provided before reassessment.	
14	The support document .reference, sample papers, questions etc. were appropriate.	
C	CLASS ROOM MANAGEMENT	
15	THE use of small groups /pair work during each activity was appropriate.	
16	The seating arrangement facilitated learning.	
17	The use of audio –visual and tech materials was effective.	
18	The teacher divided his or her attention among students appropriately.	

19	Student participation was good.	
20	Ice-breaking activities before commencement of lecture?	
D	CLASS ROOM ATMOSPHERE	
21	Student participation was active and lively.	
22	The class atmosphere was warm, open and accepting.	
23	The teacher was sensitive to student's difficulties and abilities.	
24	Students were motivated for participation during lecture delivery.	
25	Please compare this class with other classes of your course and rate.	
Note: Please use the back of this page to write comments/remarks		

Table 1: Performa of teaching feedback.

Teaching feedback by students

Keeping a record of faculty activities and insights from seeking feedback on faculty teaching and units is an essential aid to reflection, particularly over time as memory inevitably dims. Such records help in going through the cycle of clarifying teaching goals, identifying strengths and weaknesses in achieving these goals, narrowing down any areas for improvement, devising courses of action for improvement and reflecting on these changes as they are put into practice. The Performa of teaching feedback by students are in Table 1.

Teaching learning activity

Lectures, seminars, tutorials, practical, contact hours undertaken taken as percentage of lectures allocated.

Lectures or other teaching duties in excess of the UGC norms.

Preparation and Imparting of knowledge/instruction as per curriculum; syllabus enrichment by providing additional resources to students.

Use of participatory and innovative teaching-learning methodologies, updating of subject content, course improvement etc.

Examination duties (Invigilation, question paper setting, evaluation/assessment of answer scripts) as per allotment.

Percentage of lectures engaged.

Use of advanced teaching tools.

Updating of question bank.

Continuous Evaluation (Sessional /Home Assignment/Tutorial).

Percentage of syllabus covered.

Subject result of university examination

Writing effective and efficient exams is a crucial component of the teaching and learning process. Exams are a common approach to assess student learning and the results are useful in a variety of ways. Most often, results are used to provide students feedback on what they learned or evaluate the instructional effectiveness of a course. We use Table 2 Performa as evaluate subject result of university examination taught by teacher.

	Subject-1, 2, 3....
i.	Percentage of Pass Students (40%Marks<60%)
ii.	Percentage of 1st Division (60%Marks<75%)
iii.	Percentage of Distinction(75% Distinction)
iv.	Percentage of Class Average Marks

Table 2: Performa of subject result of university examination.

Academic development of teacher

Ph.D. Submitted

Passed M. Tech./MCA/MBA/M.E./M. Phil. or equivalent

Research Papers Presented in National Conference

Research Papers Presented in International Conference

Research Papers Published in National Journal

Research Papers Published in International Journal

No. of Articles published in National or International Magazines/Periodicals

Text or Reference Books Published by International Publishers with an established peer review system

Attended workshop or Faculty Development Program

Performance standard

We use Table 3 Performa as evaluate performance standard. Responsibility will be defined by Director/Institute Head. Percentage of job will be worked out on the basis of hours dedicated by a member of the team for the specific responsibility out of available 42 hours and percentage of job calculated as in Table 4.

Name of Responsibility:	Percentage of job :
Monitor by:	
Expectation :	Execution :

Table 3: Performa of performance standard.

Responsibility 1	Academic load of 18 h will become	43%
Responsibility 2	Assessment for 06 h will become	14%
Responsibility 3	Additional exam duty or other academic assignment of 10 h	24%
Responsibility 4	Administrative duty and other 08 h	19%

Table 4: Calculating percentage of job.

Other contribution

Points given by Director/Principal for extra contribution such as discipline/social etc.

Points given by Head of the Department (HOD) for extra efforts at departmental level (Table 5).

Membership of Professional Bodies (UGC/ISTE/AICTE etc.)

Maintaining good record

Involvement in TG/Forum/CT/III/Alumni

Worked as in charge and as a Member of committees like Examination / Admission / Maintenance / Warden / Any Portfolio Assigned by Director/Principal

Organizing Industry Visits/Tours/Seminars/Short Term Training Program

INPUT/ NAME	OUTPUT	RANGE	LINGUISTIC	PARAMS
TEACHING FEEDBACK BY STUDENTS (TFS)		[0 20]	POOR	[0 8 12]
			FAIR	[8 12 17]
			GOOD	[12 17 20]
			OUTSTANDING	[17 20 23]
TEACHING LEARNING ACTIVITY (TLA)		[0 20]	IRRELEVANT	[0 10 15]
			RELEVANT	[10 15 20]
			MOST RELEVANT	[15 20 25]
SUBJECT RESULT OF UNIVERSITY EXAMINATION (SRUE)		[0 20]	POOR	[0 10 15]
			GOOD	[10 15 20]
			EXCELLENT	[15 20 25]
ACADEMIC DEVELOPMENT OF TEACHER (ADT)		[0 15]	POOR	[0 8 12]
			GOOD	[8 12 15]
			VERY GOOD	[12 15 18]
PERFORMANCE STANDARD (PS)		[0 15]	NOT SATISFACTORY	[0 5 9]
			MARGINAL	[5 9 12]
			EXPECTED	[9 12 15]
			EXCELLENCE	[12 15 18]
OTHER CONTRIBUTION (OC)		[0 10]	SUGGESTIVE	[0 5 8]
			MANAGEABLE	[5 8 10]
			OPTIMAL	[8 10 12]
TEACHING PERFORMANCE (TP)		[0 60]	UNSATISFACTORY(US)	[0 30 40]
			SATISFACTORY (S)	[30 40 50]
			ACCOMPLISHED (A)	[40 50 60]
			EXEMPLARY (E)	[50 60 70]
ACADEMIC and ADMINISTRATIVE PERFORMANCE (AAP)		[0 40]	WORST	[0 20 28]
			GOOD	[20 28 35]
			BETTER	[28 35 40]
			BEST	[35 40 45]

Table 5: Input/output variables.

As shown in Figure 3, there are four membership functions such as poor, fair, good and outstanding for input teaching feedback by students. As shown in Figure 4, there are three membership functions such as irrelevant, relevant, and most-relevant for input teaching learning activity. As shown in Figure 5, there are three membership functions such as poor, good, and excellent for input subject result of university examination. As shown in Figure 6, there are four membership functions such as unsatisfactory (US), satisfactory (S), accomplished (A) and exemplary (E) for output teaching performance. As shown in Figure 7, there are three membership functions such as poor, good, and vary-good for input academic development of teacher. As shown in Figure 8, there are four membership functions such as non-satisfactory, marginal, expected and excellence for input performance standard. As shown in Figure 9, there are three membership functions such as suggestive, marginal, and optimal for input other contribution. As shown in Figure 10, there are four membership functions such as worst, good, better and best for output academic and administrative performance. Each input and output fuzzy variable is design using triangular membership function. Each value of the input variables calculated using the points given in (A), (B), (C), (D), (E), (F) and assigned by Institute Director/Head. Value of each input variable cannot exceed the maximum value.

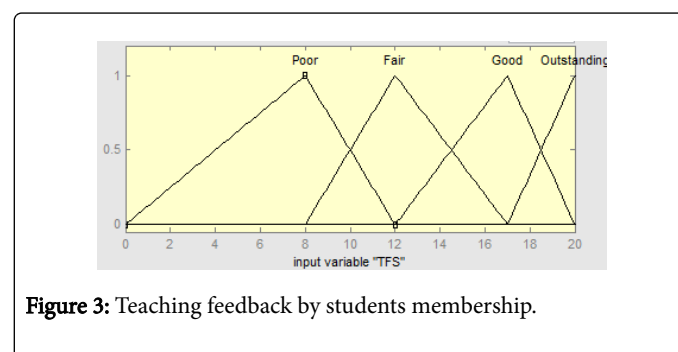

Figure 3: Teaching feedback by students membership.

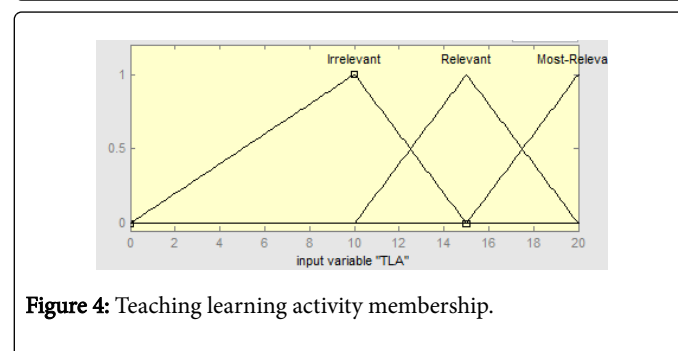

Figure 4: Teaching learning activity membership.

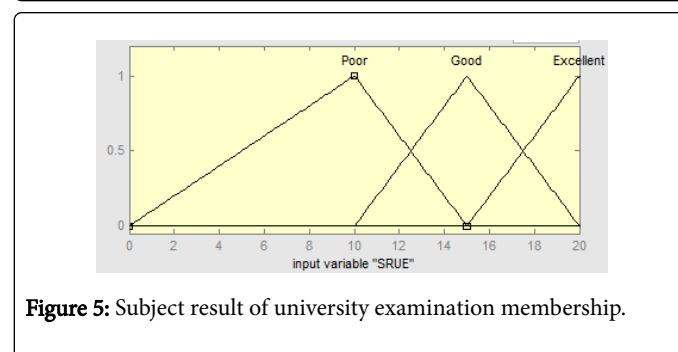

Figure 5: Subject result of university examination membership.

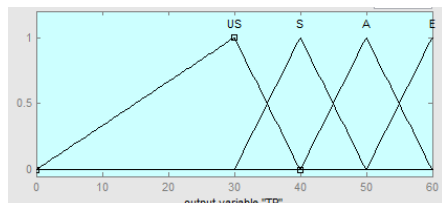

Figure 6: Teaching performance membership.

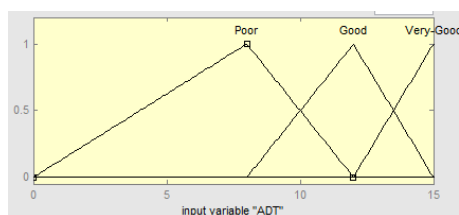

Figure 7: Academic development of teacher membership.

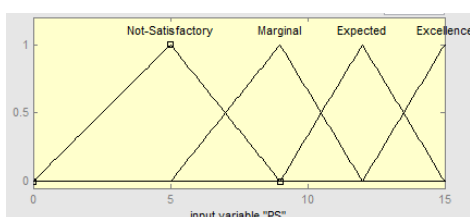

Figure 8: Performance standard membership.

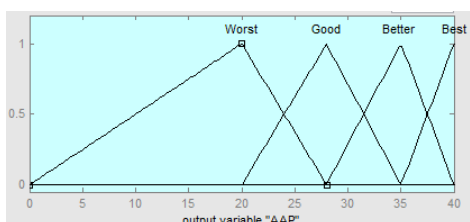

Figure 9: Academic and administrative performance membership.

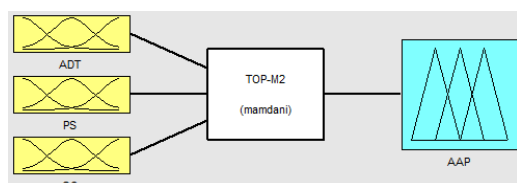

Figure 10: The whole design structure of TOP-M2 using Mamdani method.

Fuzzy Rules and Defuzzification

The inference mechanism in the fuzzy logic controller resembles that of the human reasoning process. Fuzzy logic technology is associated with artificial intelligence. In soft computing model for evaluating teachers' overall performance using fuzzy logic, we develop two different modules namely teachers' overall performance module-1 (TOP-M1) and teachers' overall performance module-2 (TOP-M2). In TOP-M1 and TOP-M2 36 fuzzy rules have been developed in MATLAB. The fuzzy rules were built using knowledge and experience of experts. The some fuzzy rules are used for designing TOP-M1 and TOP-M2 shown in the Figures 11 and 12 respectively.

1. If (TFS is Poor) and (TLA is Irrelevant) and (SRUE is Poor) then (TP is US) (1)
2. If (TFS is Poor) and (TLA is Irrelevant) and (SRUE is Good) then (TP is US) (1)
3. If (TFS is Poor) and (TLA is Irrelevant) and (SRUE is Excellent) then (TP is S) (1)
4. If (TFS is Poor) and (TLA is Relevant) and (SRUE is Poor) then (TP is US) (1)
5. If (TFS is Poor) and (TLA is Relevant) and (SRUE is Good) then (TP is S) (1)
6. If (TFS is Poor) and (TLA is Relevant) and (SRUE is Excellent) then (TP is S) (1)
7. If (TFS is Poor) and (TLA is Most-Relevant) and (SRUE is Poor) then (TP is S) (1)
8. If (TFS is Poor) and (TLA is Most-Relevant) and (SRUE is Good) then (TP is S) (1)
9. If (TFS is Poor) and (TLA is Most-Relevant) and (SRUE is Excellent) then (TP is A) (1)
10. If (TFS is Fair) and (TLA is Irrelevant) and (SRUE is Poor) then (TP is US) (1)

Figure 11: Fuzzy rules for TOP-M1 develop in MATLAB.

1. If (ADT is Poor) and (PS is Not-Satisfactory) and (OC is Suggestive) then (AAP is Worst) (1)
2. If (ADT is Poor) and (PS is Not-Satisfactory) and (OC is Manageble) then (AAP is Worst) (1)
3. If (ADT is Poor) and (PS is Not-Satisfactory) and (OC is Optimal) then (AAP is Worst) (1)
4. If (ADT is Poor) and (PS is Marginal) and (OC is Suggestive) then (AAP is Worst) (1)
5. If (ADT is Poor) and (PS is Marginal) and (OC is Manageble) then (AAP is Good) (1)
6. If (ADT is Poor) and (PS is Marginal) and (OC is Optimal) then (AAP is Good) (1)
7. If (ADT is Poor) and (PS is Expected) and (OC is Suggestive) then (AAP is Good) (1)
8. If (ADT is Poor) and (PS is Expected) and (OC is Manageble) then (AAP is Good) (1)
9. If (ADT is Poor) and (PS is Expected) and (OC is Optimal) then (AAP is Good) (1)
10. If (ADT is Poor) and (PS is Excellence) and (OC is Suggestive) then (AAP is Good) (1)

Figure 12: Fuzzy rules for TOP-M2 develop in MATLAB.

In the fuzzy logic controller once the appropriate rules are fired, the degree of membership of the output fuzzy variable i.e., teaching performance is determined by encoding the antecedent fuzzy subsets in this case teaching feedback by students, teaching learning activity, subject result of university examination and the output fuzzy variable i.e., academic and administrative performance is determined by encoding the antecedent fuzzy subsets, in this case academic development of teacher, performance standard, other contribution. In soft computing model for evaluating teachers' overall performance fuzzy logic the max-min implication technique is used. Using this technique the final output membership function for each rule is the fuzzy set assigned to that output by clipping the degree of truth values of the membership functions of the associated antecedents. Once the membership degree of each output fuzzy variable is determined all of the rules that are being fired are then combined and the actual crisp output is obtained through defuzzification. The procedure of converting each aggregated fuzzy output set into a single crisp value is called defuzzification. In soft computing model for evaluating teachers' overall performance we use centroid defuzzification method.

Simulation Result and Discussion

After a soft computing model for evaluating teachers' overall performance was carefully designed, we test the system and discuss the impact of the input variables on the output variable. Fuzzy logic toolbox provides an advantage of representing the fuzzy rules in a 3-dimensional form with the help of surface viewer. With the help of simulation, we show the effect of the three inputs teaching feedback by

students (TFS), teaching learning activity (TLA), subject result of university examination (SRUE) and academic development of teacher (ADT), performance standard (PS), other contribution (OC) to resulted teaching performance (TP) and academic and administrative performance (AAP) respectively.

A surface viewer for knowledge analysis is as shown in Figure 13, the teaching performance (TP) is in z-axis is small when the value of teaching feedback by students (TFS) is in x-axis and teaching learning activity (TLA) is in y-axis have a small value. The teaching performance (TP) grows fastly and gets a maximum value when the teaching feedback by students (TFS) side is being too many and the teaching learning activity (TLA) density become small. On the other hand, teaching performance (TP) grows fastly and gets a maximum value when the teaching feedback by students (TFS) side is being small and the teaching learning activity (TLA) density become too large.

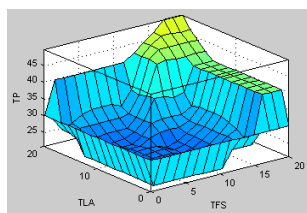

Figure 13: Input variables TFS, TLA Vs output variable TP.

As shown in Figure 14, the teaching performance (TP) is in z-axis takes same functioning with respect to teaching feedback by students (TFS) is in x-axis and subject result of university examination (SRUE) is in y-axis as in Figure 13.

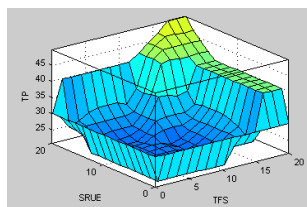

Figure 14: Input variables TFS, SRUE Vs output variable TP.

As shown in Figure 15, the teaching performance (TP) is in z-axis and teaching learning activity (TLA) is in x-axis and subject result of university examination (SRUE) is in y-axis.

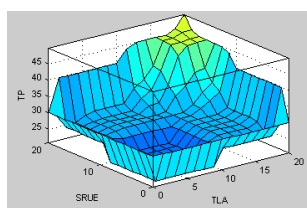

Figure 15: Input variables TLA, SRUE vs. output variable TP.

As shown in Figure 16, the academic and administrative performance (AAP) is in z-axis and academic development of teacher (ADT) is in x-axis and performance standard (PS) is in y-axis.

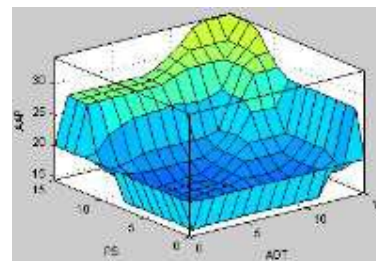

Figure 16: Input variables ADT, PS vs. output variable AAP.

As shown in Figure 17, the academic and administrative performance (AAP) is in z-axis and performance standard (PS) is in y-axis and other contribution (OC) is in x-axis.

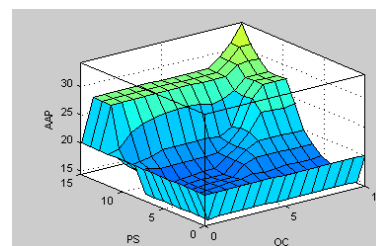

Figure 17: Input variables OC, PS vs. output variable AAP.

As shown in Table 5, this yields the comparison of conventional and fuzzy system for evaluating teachers' overall performance. First we calculate teaching performance (TP) with the help of inputs teaching feedback by students (TFS), teaching learning activity (TLA) and subject result of university examination (SRUE) using TOP-M1 as in Figure 18 for both the system. Secondly we calculate academic and administrative performance (AAP) with the help of inputs academic development of teacher (ADT), performance standard (PS) and other contribution (OC) using TOP-M2 as in Figure 19 for both the system. Teaching performance and academic and administrative Performance were combined to give overall performance. Last two columns of Table 6 shows the values of teachers' overall performance by conventional and fuzzy system respectively.

We observed the difference in the direct value and the values determined by using fuzzy model. This is due to the weightage given on some important inputs related to teaching learning process and overall development of the institute while framing the rules. Hence the teachers' overall performance determined by fuzzy system is more realistic than the conventional system.

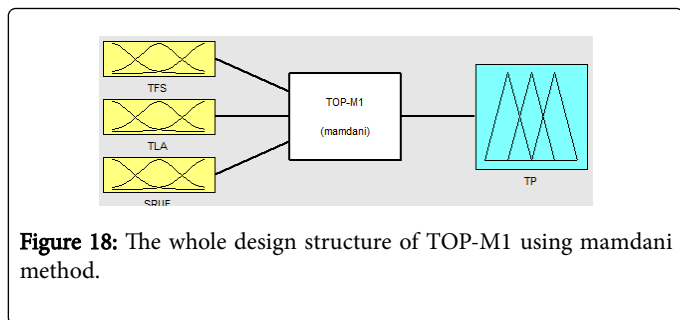

Figure 18: The whole design structure of TOP-M1 using mamdani method.

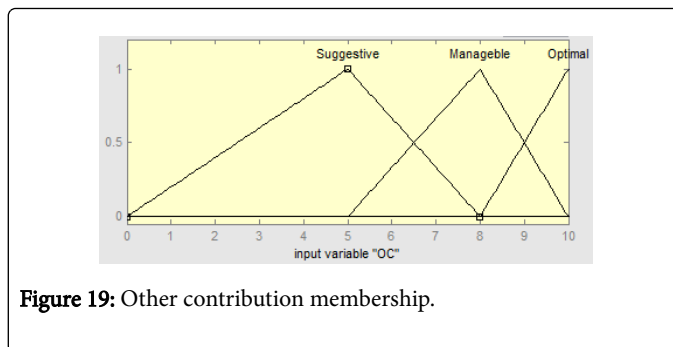

Figure 19: Other contribution membership.

TFS	TLA	SRUE	ADT	PS	OC	Teaching Performance		Academic and Administrative		Overall performance	
						Conventional	TOP-M1	Conventional	TOP-M2	Conventional System	Fuzzy System
12	15	15	7	5	5	42	40	17	16	59	56
14	14	14	12	9	8	42	39	29	28	71	67
18	17	17	13	13	9	52	51	35	35	87	86
12	15	15	15	15	10	42	40	40	39	82	79
8	20	20	15	15	8	48	50	38	38	86	88
20	10	10	15	5	10	40	40	30	28	70	68
15	15	15	4	3	3	45	45	10	13	55	58
20	20	20	7	4	4	60	57	15	16	75	73
19	18	18	12	9	8	55	52	29	28	84	80
18	17	17	13	13	9	52	51	35	35	87	86
17	16	16	15	15	10	49	50	40	39	89	89
4	8	8	15	15	8	20	22	38	38	58	60

Table 6: Comparison of conventional and fuzzy system.

Conclusion and Future Works

We should note that soft computing technologies are relatively young. Neural network was originated in 1959, fuzzy logic in 1965, probabilistic reasoning started in 1967 with Dempster's, Genetic algorithms in 1975 and in early 80s with Pearl's work. The result is the development of hybrid algorithms that are superior to each of their underlying soft computing components and that provide us with the better real world problem solving tools. It can be observed from the result that a soft computing model for evaluating teachers' overall performance using fuzzy logic provide better performance than conventional model. A large number of factors affecting the teachers' overall performance were identified and incorporated in the system. The proposed system can be more improved and used for evaluating performance of other staff. Some other optimization techniques such as artificial neural networks (ANN), neuro fuzzy systems and genetic algorithms (GA) can also be employed for effective evaluating teachers' overall performance.

Acknowledgements

We are thankful to our management of Amrapali Institute of Management and Computer Applications one of the reputed Amrapali Group of Institutes located in Haldwani Nainital, Uttrakhand, India for providing the data to develop a soft computing model for evaluating teachers' overall performance using fuzzy logic.

References

1. Bonissone PP (1997) Soft computing: the convergence of emerging reasoning technologies. Springer-Verlag 1: 6-18.
2. Khan AR, Amin HU, Rehman ZU (2011) Application of Expert System with Fuzzy Logic in Teachers' Performance Evaluation. International Journal of Advanced Computer Science and Applications.
3. Alam J, Pandey MK (2014) Advance traffic light system based on congestion estimation using fuzzy logic. International Journal of Emerging Technology & Advanced Engineering 4: 870-877.
4. Pavani S, Gangadhar PVSS, Gulhare KK (2012) Evaluation of teacher's performance using fuzzy logic techniques. International Journal of Computer Trends and Technology 3: 200-205.

-
5. Bhosale G, Kamath RS (2013) Fuzzy inference sytem for teaching staff performance appraisal. International Journal of Computer and Information Technology 2: 381-385.
 6. Jyothi G, Parvathi C, Srinivas P, Althaf Rahaman SK (2014) Fuzzy expert model for evaluation of faculty performance in technical educational institutions. Journal of Engineering Research and Applications 4: 41-50.
 7. Gokmen,G, Akinci TC, Tektas M, Onat N, Kocyigit G, et al. (2010) Evaluation of student performance in laboratory applications using fuzzy logic. Procedia Social and Behavioral Science, pp: 902-909.
 8. Kamath RS (2014) Design and development of soft computing model for teaching staff performance evaluation. International Journal of Engineering Sciences & Research Technology 3: 3088-3094.
 9. Othman M, Ku-mahamud KR, Bakar AA (2008) Fuzzy evaluation method using fuzzy rule approach in multicriteria analysis. Yugoslav Journal of Operations Research 1: 95-107.
 10. Alam, J, Pandey MK (2015) Design and analysis of a two stage traffic light system using fuzzy logic. Journal of Information Technological and Software Engineering.